



M
O
D
U
L
A
R



GERMAN
DESIGN
AWARD
SPECIAL
2023

+
DESIGN
COUNTERS

Shaping inspiration

ROSSKOPF
+ PARTNER

HIGH QUALITY
BARRIER FREE
RELIABLE
PLANNING
DURABLE
COST AND TIME
EFFICIENCY

CONTENTS

miru® - Customisable Design Counters	3 - 14
Carve	15 - 24
Concave	25 - 34
Cube	35 - 44
Flow	45 - 54
Mountain	55 - 64
Prisma	65 - 74
Stage	75 - 84
Warp	85 - 94
Craftsmanship Meets Architecture	95 - 102





CUSTOMISABLE
DESIGN COUNTERS

miru[®]

Together with Vietzke & Borstelmann Architects we have developed the product range miru[®]: a modular system with which you can configure individual counter solutions quickly and easily for any room situation.

miru[®] is derived from the English and stands for:

modular - a modular product system
infinite - infinite possibilities
reception desk - reception desks with
unique - unusual designs and material combinations.

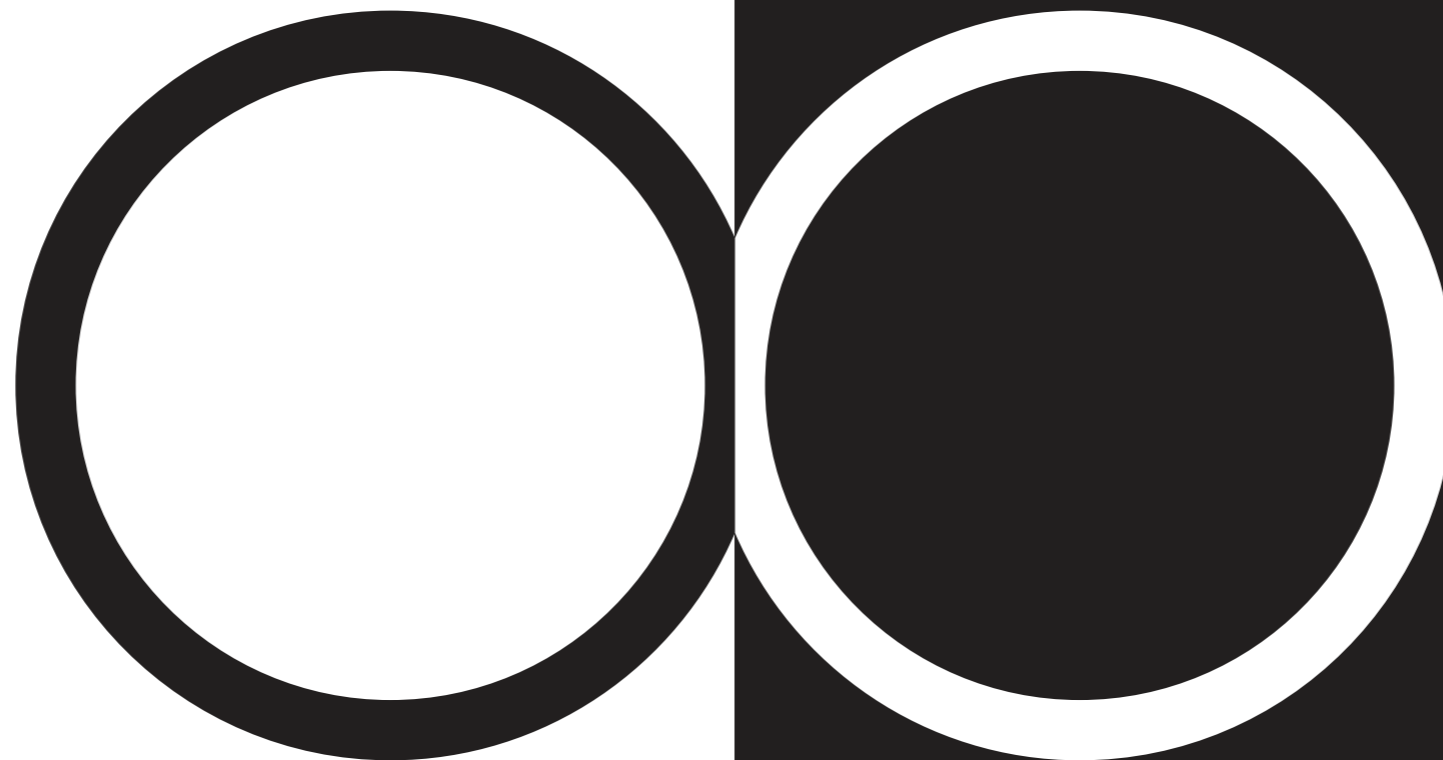

ROSSKOPF + PARTNER

designed by
Vietzke & Borstelmann
Architects

INFINITE

POSSIBILITIES

VIETZKE & BORSTELMANN ARCHITECTS

As a pioneer in the solid surfaces segment, we have been working closely with top architects and designers for decades to bring unique design worlds to life together. Thomas Vietzke and Jens Borstelmann have been collaborating with us for many years in a spirit of mutual trust. A partnership which began with the large-scale project Hotel Puerta America and Zaha Hadid has now broadened to include a jointly developed product system.

Vietzke & Borstelmann Architects are a byword for innovative and customised architecture. Their designs are lent a natural aesthetic thanks to their use of complex shapes and geometrics. The office is headed by Thomas Vietzke and Jens Borstelmann, who met during their time at Zaha Hadid Architects.

They completed numerous award-winning designs and projects in London and Hamburg between 2001 and 2014, before founding their own office in Hamburg in 2014. The merging of digital techniques with conventional craftsmanship and a passion for innovative, sustainable materials have characterised their work for many years.



Project: Hotel Puerta America, Madrid (2004/2005)
Design: Zaha Hadid
Description: large-scale project with intricately-designed cladding made of solid surface material

DESIGN LINES

The range of the modular counter system includes eight different, exclusive design lines. The spectrum ranges from puristic simplicity, through refined complexity, to timeless elegance. The design language reflects creative pairs of opposites.

MINIMALIST	NEO-BAROQUE
CLASSICAL MODERN	FUTURISTIC
NATURAL	ARTIFICIAL
EXPRESSIVE	RESERVEDLY CALM

Each design line features a large number of individual modules which can be combined according to your needs and requirements.

The size variability enables it to be used in different spatial contexts. It starts with small scales, for example, with a doctor's office, a reception room in a law firm or in a boarding house; then it continues up to large configurations for hall-like lobbies in office buildings, hotels, cultural settings and public buildings.

Between these poles, you can also create a large number of medium-sized counters that can be used, for example, in upscale catering and event areas, in banks or in business clubs.

You always receive a unique piece that is tailored to your needs and, at the same time, you can enjoy the economic and qualitative advantages of modular prefabrication.

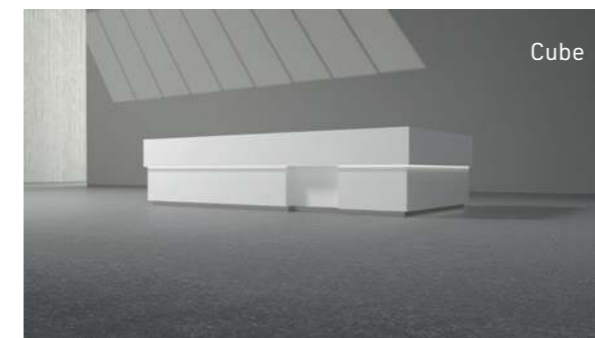
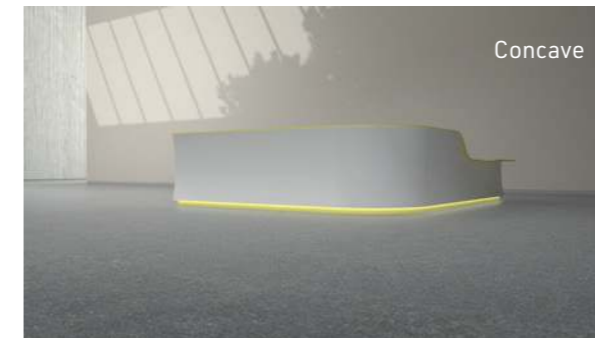

PREMIUM

DESIGN

WHAT ARE YOUR REQUIREMENTS?

A miru® counter can be configured individually. Depending on the design line selected, you can choose from 8 to 29 different modules, material combinations and / or colour options matching the design, with various additional options also available as required.

Plan your individual design counter now.

- Step 1:** Select a design line
- Step 2:** Select the modules
- Step 3:** Choose the colour or decor
- Step 4:** Select the joint design
- Step 5:** Select additional options

JOINT DESIGN

You decide whether the modules are assembled with a visible design joint or are delivered joint-free. Joint-free processing of the material in one piece (including delivery) is possible at the factory up to a length of 4 metres and a width of 1.2 metres. If delivery of a joint-free product is not possible, the modules can be combined, bonded together, and sanded to a smooth gap-free finish on site for an additional charge.



MODULE SELECTION

There are 8 to 29 modules to choose from depending on the design line. Please refer to the respective data sheets for an overview of the modules available for each series.



ADDITIONAL OPTION - Logo

The corporate logo can be integrated into the front panel in the case of selected design lines.



COLOUR OPTIONS

standard

The base material used for the design counters is usually a white solid surface material.

colour accents

Optionally, the white solid surface material can be combined with a coloured equivalent or with natural materials such as ceramic, natural stone or UPB® Board.

This creates unique material contrasts and detailed connections.

Example Curve:

Here, the countertop can be upgraded with wood-like UPB® Board.

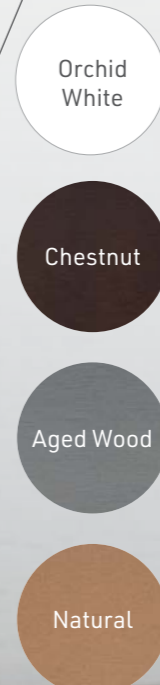

ADDITIONAL OPTION BACK OFFICE SOLUTIONS

Equipment including cable passages, compartments and standing containers are available for workspaces (see price list).

ADDITIONAL OPTION BASE LIGHTING

Base lighting is also available:

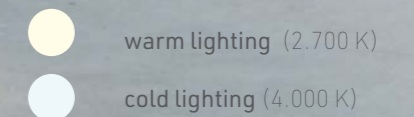

INDIVIDUALITY

SUSTAINABILITY

miru® relies on particularly durable and robust materials with hard-wearing surfaces: flexible, repairable solid surface material combined with natural and recyclable materials.

Because they are modular, the reception counters can be expanded and adapted even after many years.

NATURAL STONE

- + UNIQUE
- + SOPHISTICATED
- + ROBUST

SOLID SURFACE MATERIAL

- + ORGANICALLY MALLEABLE
- + HYGIENIC
- + REPAIRABLE

CERAMICS

- + SCRATCH-RESISTANT
- + EASY TO CLEAN
- + MATTE FINISH

UPB® BOARD

- + NATURAL FIBRE*
- + WOOD FINISH
- + WATERPROOF

* made from rice husks



AT A GLANCE

Get an overview of the special features of the individual design lines.

	CARVE	CONCAVE	CUBE	FLOW	MOUNTAIN	PRISMA	STAGE	WARP
Number Of Available Modules	29	27	22	22	22	22	8	8
Lowered Modules Available	•	•	•	•		•		•
Accessible Modules Available	•	•				•		
Standard Design	white solid surface material	white solid surface material	white solid surface material	white solid surface material	white solid surface material with ceramic in the front panel, decor: New York-New York	white solid surface material	white solid surface material with countertop in natural stone, Nero Assoluto	white solid surface material
Special Feature (Material, Colours + Decors)	optional countertop made of UPB® Board, choose from 3 different decors	optional coloured countertop + base made of solid surface material, choose from 2 further colours	available in 4 colour combinations	available in 3 colour combinations, base colour selectable	combination of folded solid surface material + ceramic, choose from 5 ceramic decors	optional ceramic inlays in countertop + front panel, choose from 3 different decors	combination of white solid surface material + Nero Assoluto natural stone	optional synergy3D plaster strips, choose from 3 different decors
Option: Joint-free	•	•	•	•	•	•	•	•
Option: Design Joint	bevel 2x2 mm	radius 3 mm	bevel 2x2 mm	radius 3 mm	bevel 2x2 mm	bevel 2x2 mm	radius 3 mm	bevel 2x2 mm
Additional Option: Base Lighting	•	•	•	•	•	•	•	•
Accent Lighting (Included As Standard)								
Additional Option: Logo Milling	in module CAR-S-U-900	in module CON-S-U-900	in module CUB-S-U-900	in module FLO-S-U-900	possible in the coloured area	no logo possible	no logo possible	no logo possible
Additional Option: Logo Attachment	•	•	•	•	•	•	•	•
Additional Option: Back Office Solutions					on ceramic surface			
Base Colour	white	white or coloured	in the colour of the lower body	white or coloured, the colour of the lower body in the case of two-tone option	stainless steel finish	white	white	white
Design-specific Modules	Cantilever CAR-LC, CAR-RC	Curve Upstand (not only curved in the front panel) CON-C-U-1800, CON-C-U-900	Cloudhanger CUB-S-U-CH	S-Curve Upstand FLO-LSCU, FLO-RSCU	all modules with folded solid surface material + ceramic	Cantilever PRI-LC, PRI-RC	small + large waves in straight modules STG-S-AL, STG-S-BL, STG-S-B5, STG-S-AS	all modules with curved + indented surfaces



CABWE

COUNTERTOP MADE OF
UPB BOARD

HORIZONTAL
VISUAL AXIS

DIAGONAL
GRADIENTS

CARVE

Carve is characterized by a continuous horizon made of two mutually inclined surfaces. Diagonal gradients create a dynamic overall appearance and achieve an even balance of movement and counter-movement. The combination with wood-like UPB® Board* creates a natural aesthetic in the countertop.

ADDITIONAL OPTION LOGO

Your logo can be integrated into the front panel of the counter on request.

miru

milled
in module
CAR-S-U-900

miru

attached

MODULE SELECTION

There are 29 modules to choose from, including lowered and accessible modules (see page 19).



JOINT DESIGN

You decide whether the modules are assembled with a visible design joint or are delivered joint-free. Joint-free processing of the material in one piece (including delivery) is possible at the factory up to a length of 4 metres and a width of 1.2 metres. If delivery of a joint-free product is not possible, the modules can be combined, bonded together, and sanded to a smooth gap-free finish on site for an additional charge.



joint-free



design joint
bevel 2x2 mm

COLOUR OPTIONS

standard

Orchid White solid surface material

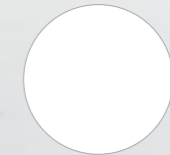

optional: UPB® Board in the countertop

Three different decors are available (see page 20).



ADDITIONAL OPTION BACK OFFICE SOLUTIONS

Equipment including cable passages, compartments and standing containers are available for workspaces (see price list).

ADDITIONAL OPTION BASE LIGHTING

Base lighting is also available:



warm lighting (2.700 K)



cold lighting (4.000 K)

BASE COLOUR
white

MODULES + DECORS

Plan your individual design counter. Choose from 29 different modules and three optional decors for the UPB® Board in the countertop as a contrast to the white solid surface material. The data sheet provides further details on the modules (e.g. dimensions and weight) as well as potential configuration examples.

End Modules



CAR-LE-U-P



CAR-RE-U-P



CAR-LE-U-ST



CAR-RE-U-ST



CAR-LE-D



CAR-RE-D

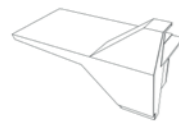

CAR-LC

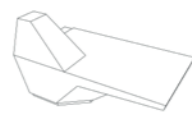

CAR-RC

Corner Modules



CAR-C90-U



CAR-C45-U



CAR-C90-D



CAR-C45-D

Straight Modules



CAR-S-U-300



CAR-S-U-600



CAR-S-U-900



CAR-S-U-1200



CAR-S-U-1500



CAR-S-U-1800



CAR-S-D-300



CAR-S-D-600



CAR-S-D-900



CAR-S-D-1200



CAR-S-D-1500



CAR-S-D-1800

Accessible Modules



CAR-UP-1500



CAR-UP-1800



CAR-UP-2100



CAR-LU



CAR-RU

Transition Modules

Standard: Solid Surface Material



ORCHID WHITE

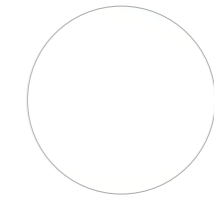

Optional: UPB® Board In The Countertop

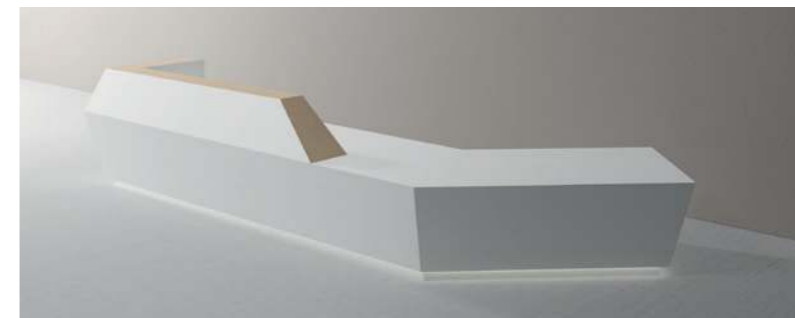

ORCHID WHITE +
NATURAL

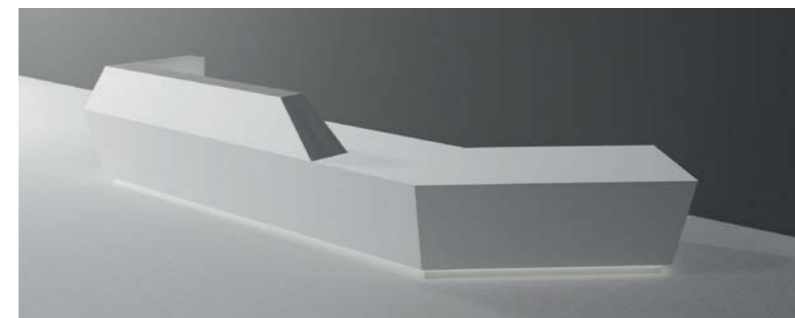
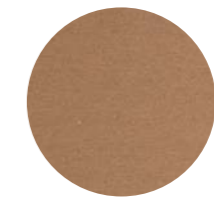

ORCHID WHITE +
AGED WOOD



ORCHID WHITE +
CHESTNUT



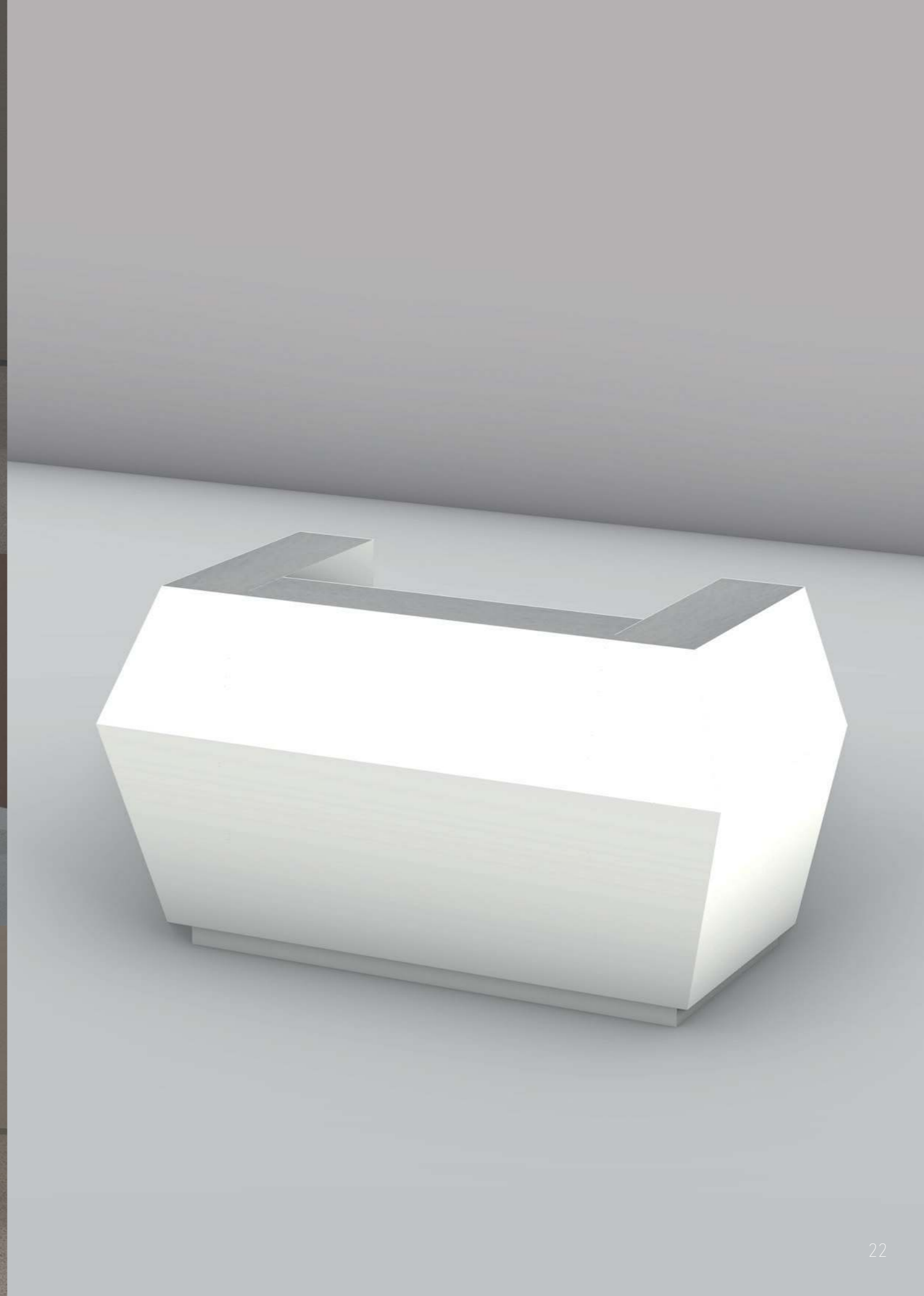
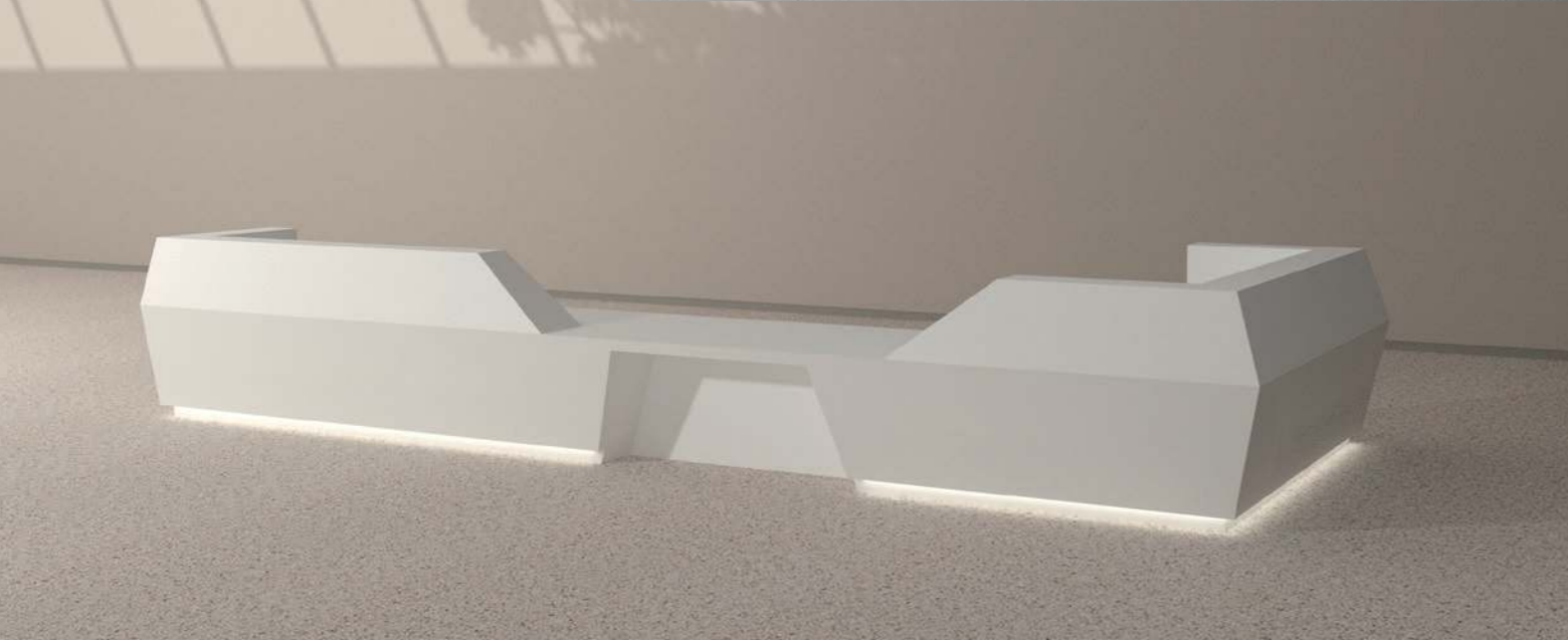
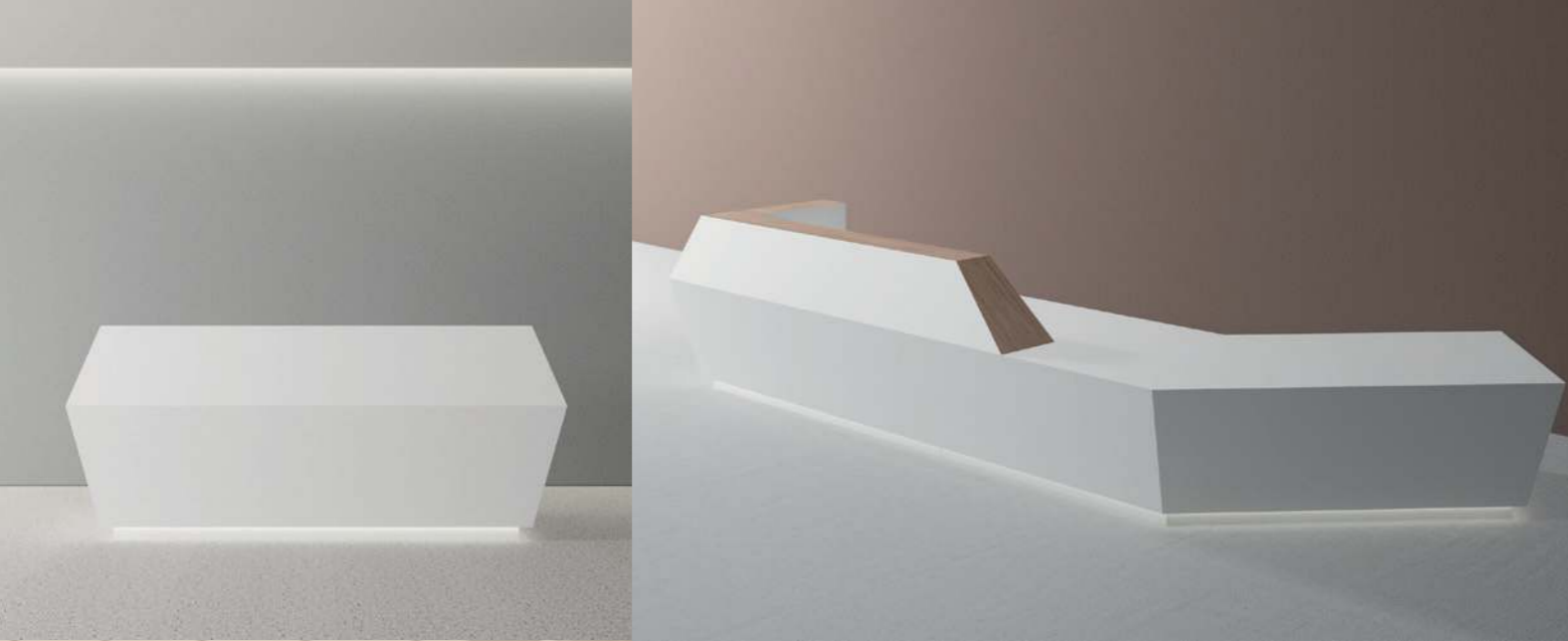





CONCOURSE

COLOURED SOLID SURFACE MATERIAL COUNTERTOP + BASE

CONCAVE-CONVEX SHAPES

CREATES AN IMPRESSION OF
LIGHTNESS

CONCAVE

Dynamically curved surfaces of concave-convex shapes underline the modern touch of the design. The fine balance of surface tensions, as in soap skins, is reflected in subtly curved and rounded surfaces. The concept of lightness and brightness is supported by fresh light colour nuances in the countertop and base, which can be ordered in this series.

ADDITIONAL OPTION BACK OFFICE SOLUTIONS

Equipment including cable passages, compartments and standing containers are available for workspaces (see price list).

ADDITIONAL OPTION LOGO

Your logo can be integrated into the front panel of the counter on request.



MODULE SELECTION

There are 27 modules to choose from, including lowered and accessible modules (see page 29).



JOINT DESIGN

You decide whether the modules are assembled with a visible design joint or are delivered joint-free. Joint-free processing of the material in one piece (including delivery) is possible at the factory up to a length of 4 metres and a width of 1.2 metres. If delivery of a joint-free product is not possible, the modules can be combined, bonded together, and sanded to a smooth gap-free finish on site for an additional charge.



COLOUR OPTIONS

standard
Orchid White solid surface material



optional: countertop + coloured base
Two different colour options are available (see page 30).



ADDITIONAL OPTION BASE LIGHTING

Base lighting is also available:

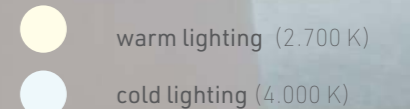

BASE COLOUR
matches the colour
of the countertop

MODULES + DECORS

Plan your individual design counter. Choose from 27 different modules. Combine the white solid surface material with an optional colour in the countertop and base. Two different colour options are available. The data sheet provides further details on the modules (e.g. dimensions and weight) as well as potential configuration examples.

End Modules



Corner Modules



Straight Modules

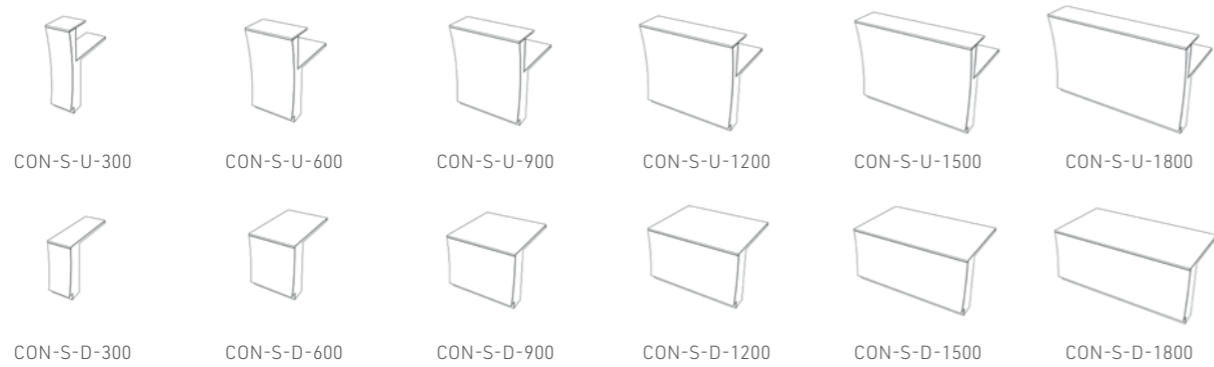

Curved Modules

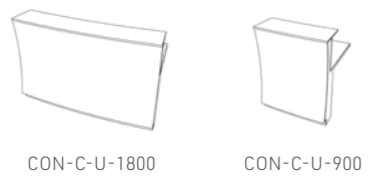

Accessible Modules

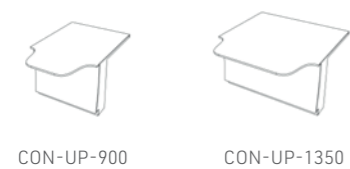

Transition Modules



Standard: Solid Surface Material

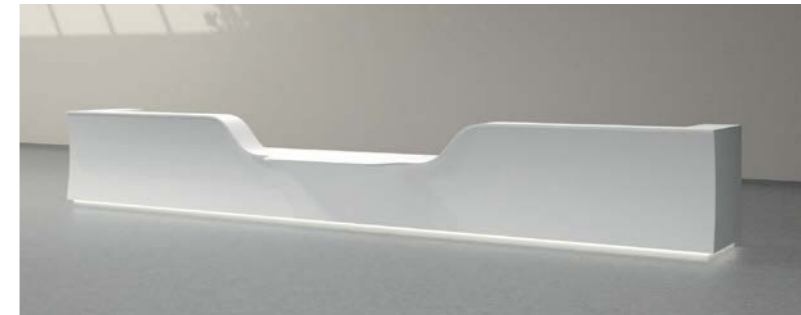

ORCHID WHITE

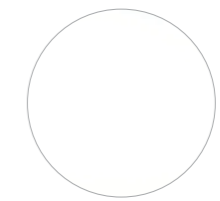

Alternative Colours For Countertop And Base

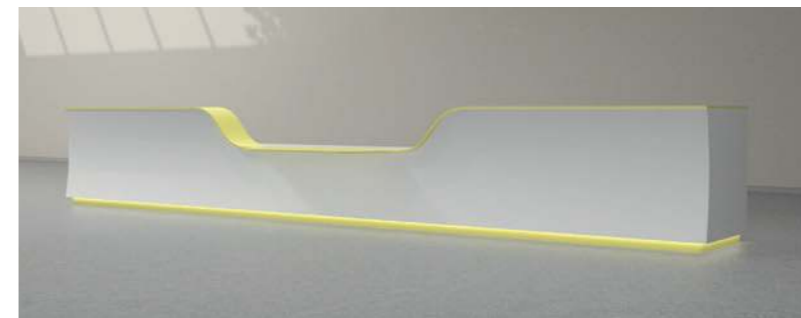

ORCHID WHITE +
SUNSHINE YELLOW

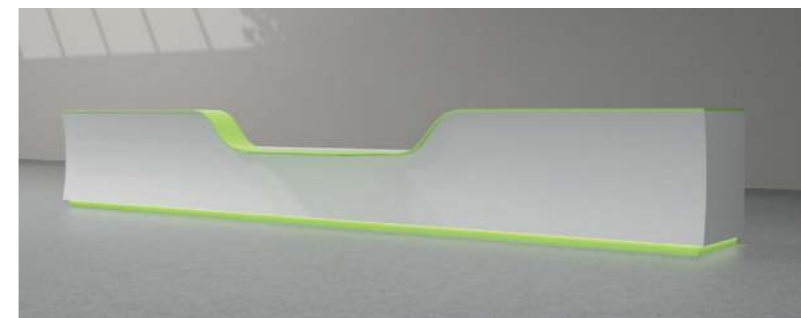
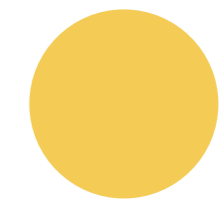

ORCHID WHITE +
LIME GREEN

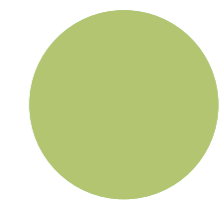

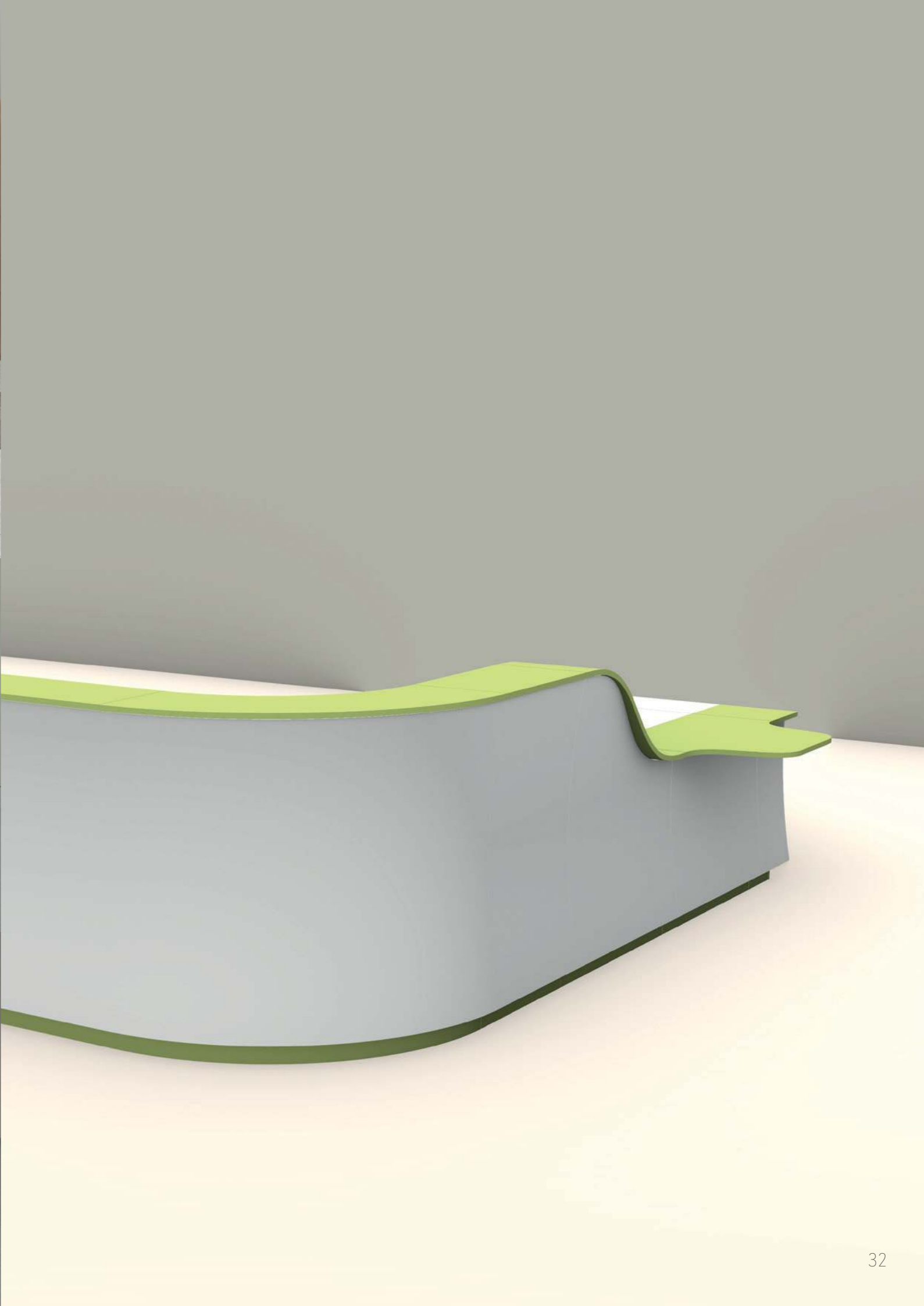
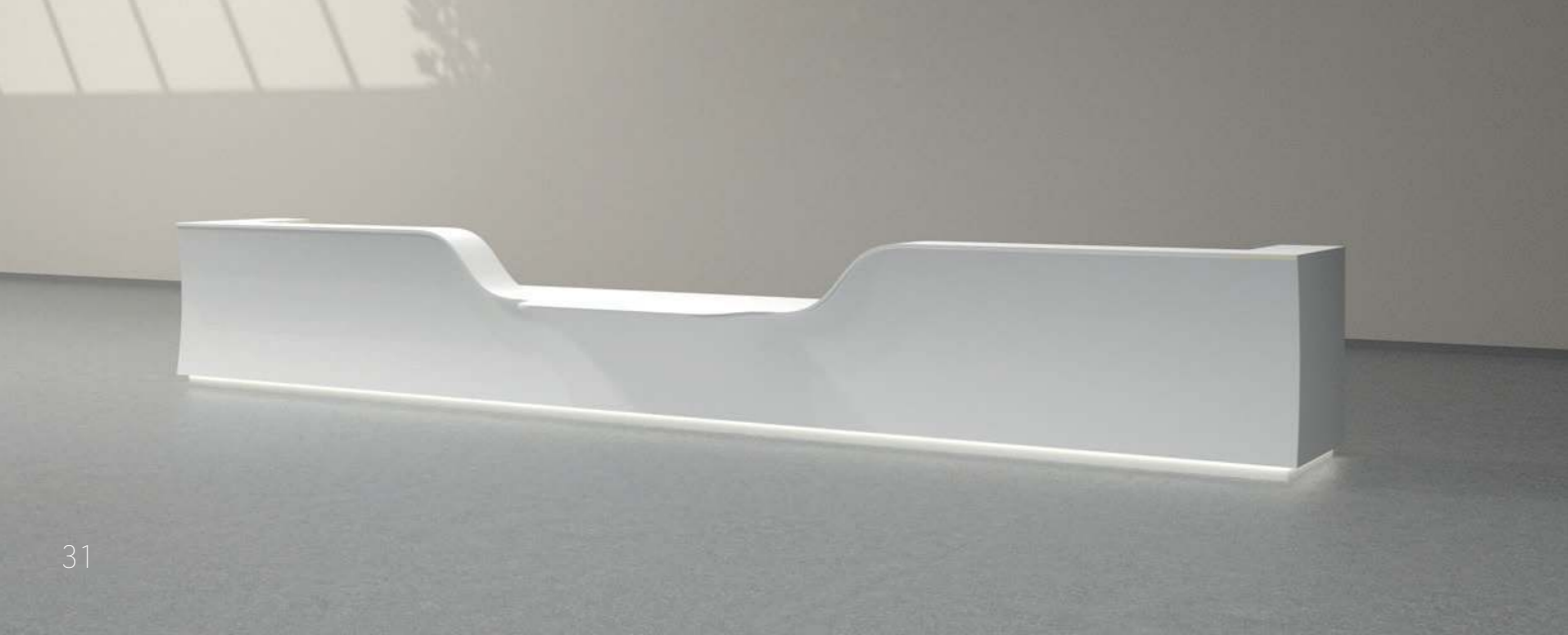





W
B
U
C

CUBIST CLARITY

INTERPLAY
OF OVERHANGING AND RECEDING AREAS

DUAL-TONE CONCEPT

CUBE

The cubist form is characterized by reduced simplicity and flat abstraction. The lower half recedes slightly behind the overhanging crown area. This plastic shift can be underlined by a darker coloured area. It is an all-rounder that blends in and withdraws, although developing a confident presence.

ADDITIONAL OPTION BACK OFFICE SOLUTIONS

Equipment including cable passages, compartments and standing containers are available for workspaces (see price list).

ADDITIONAL OPTION LOGO

Your logo can be integrated into the front panel of the counter on request.



MODULE SELECTION

There are 22 modules to choose from, including lowered modules (see page 39).



JOINT DESIGN

You decide whether the modules are assembled with a visible design joint or are delivered joint-free. Joint-free processing of the material in one piece (including delivery) is possible at the factory up to a length of 4 metres and a width of 1.2 metres. If delivery of a joint-free product is not possible, the modules can be combined, bonded together, and sanded to a smooth gap-free finish on site for an additional charge.

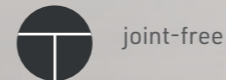

joint-free



design joint
bevel 2x2 mm

ADDITIONAL OPTION BASE LIGHTING

Base lighting is also available:



warm lighting (2.700 K)



cold lighting (4.000 K)

COLOUR OPTIONS

standard

Orchid White solid surface material



optional: colour combination

Design the upper + lower body using different coloured solid surface materials. Three other possible colour combinations are available (see page 40).

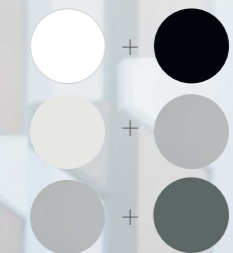

ACCENT LIGHTING

BASE COLOUR

in the colour of the lower body

MODULES + DECORS

Plan your individual design counter. Choose from 22 different modules. Create a colourful impression with a dual-tone colour combination in the solid surface material for the counter bodies. The data sheet provides further details on the modules (e.g. dimensions and weight) as well as potential configuration examples.

End Modules



CUB-LE-U-SM



CUB-RE-U-SM



CUB-LE-U



CUB-RE-U



CUB-LE-D



CUB-RE-D

Corner Modules



CUB-C90-U

Straight Modules



CUB-S-U-300



CUB-S-U-600



CUB-S-U-900



CUB-S-U-1200



CUB-S-U-1500

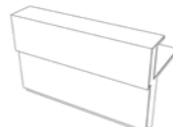

CUB-S-U-1800



CUB-S-D-300



CUB-S-D-600



CUB-S-D-900



CUB-S-D-1200



CUB-S-D-1500



CUB-S-D-1800



CUB-S-U-CH*

Transition Modules



CUB-RU



CUB-LU

Standard: Solid Surface Material



ORCHID WHITE

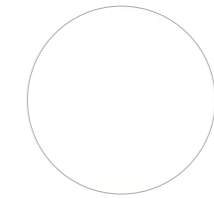

Alternative Colour Combinations



ORCHID WHITE +
CURRANT BLACK

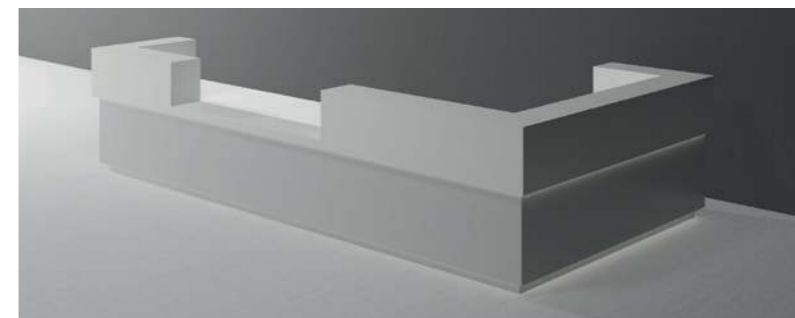
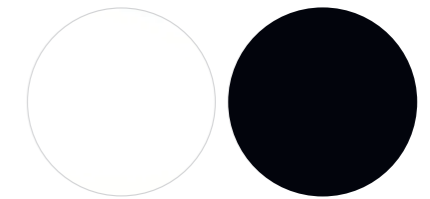

LIGHT GREY +
SLATE GREY

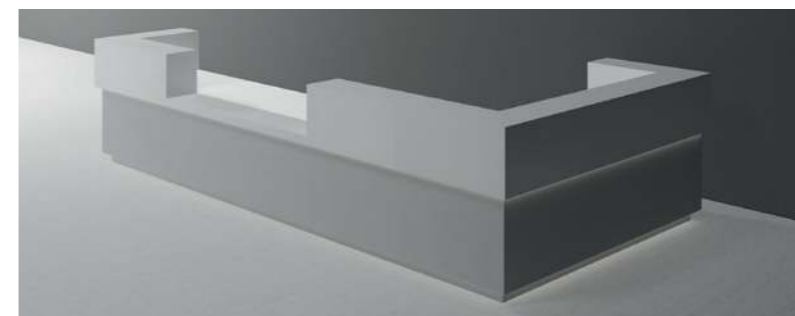

SLATE GREY +
BASALT GREY

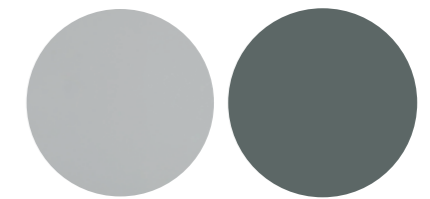

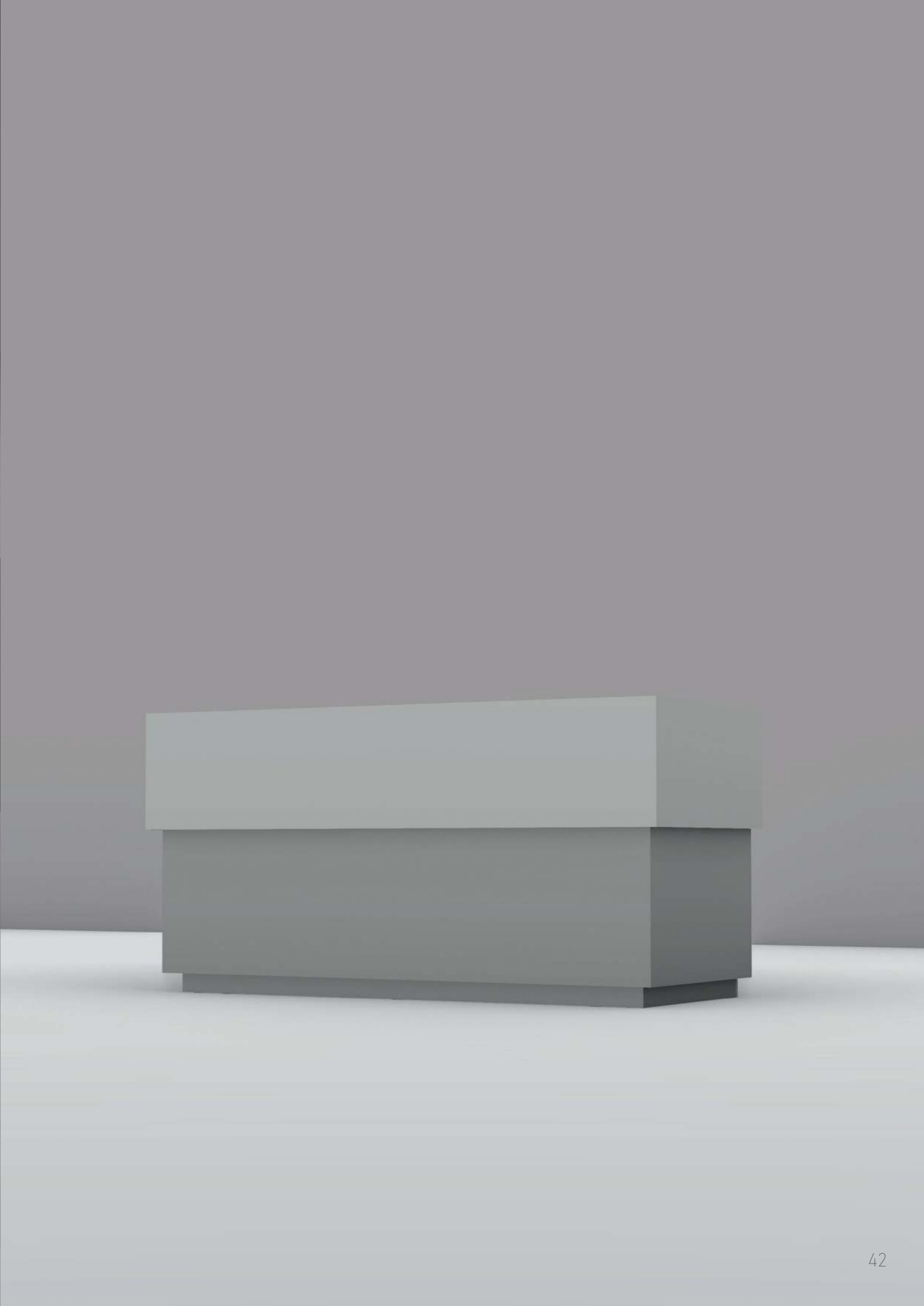
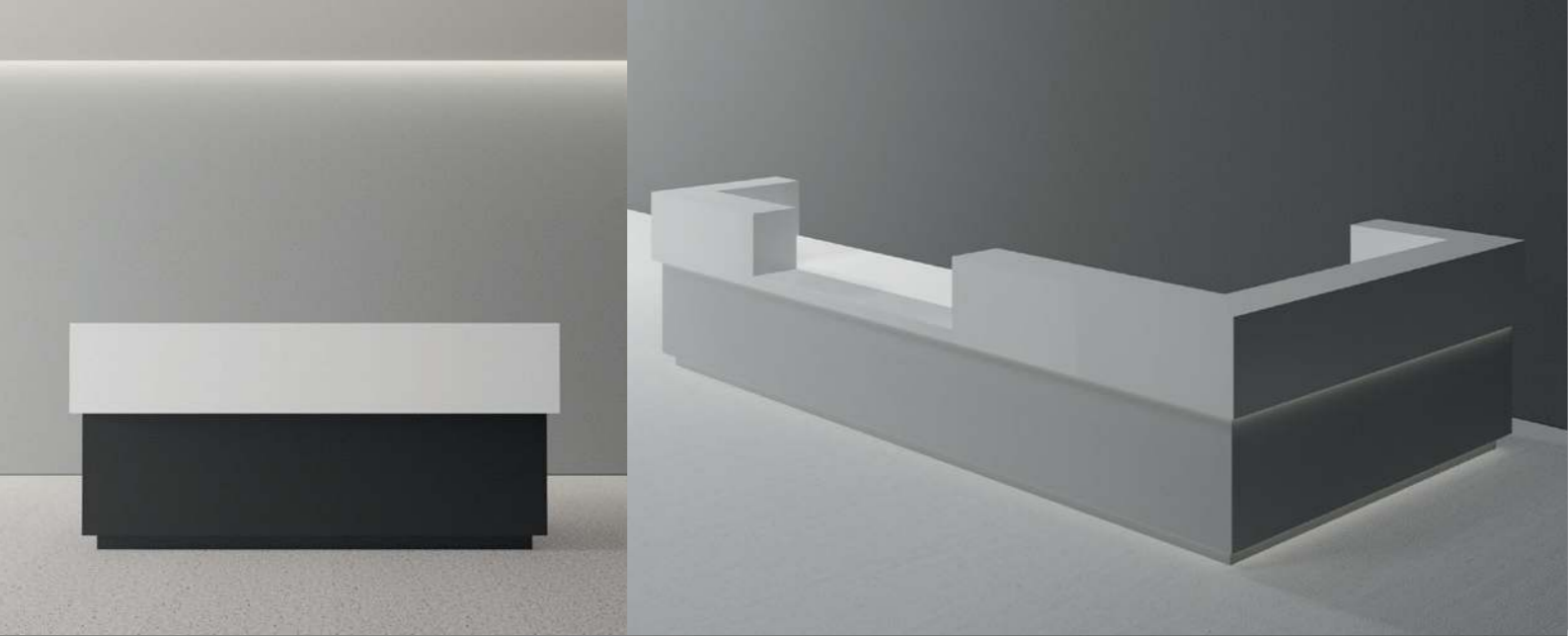
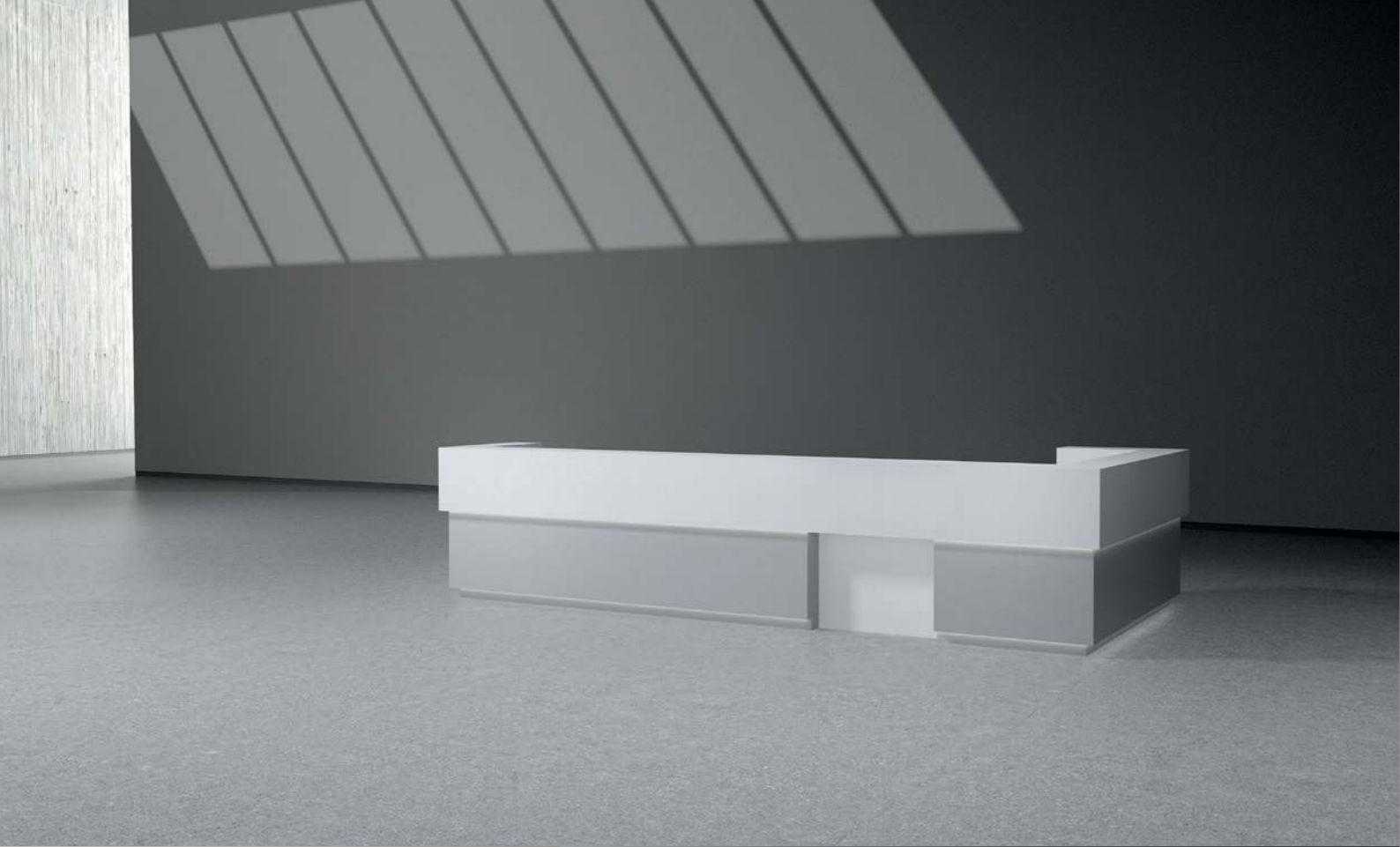

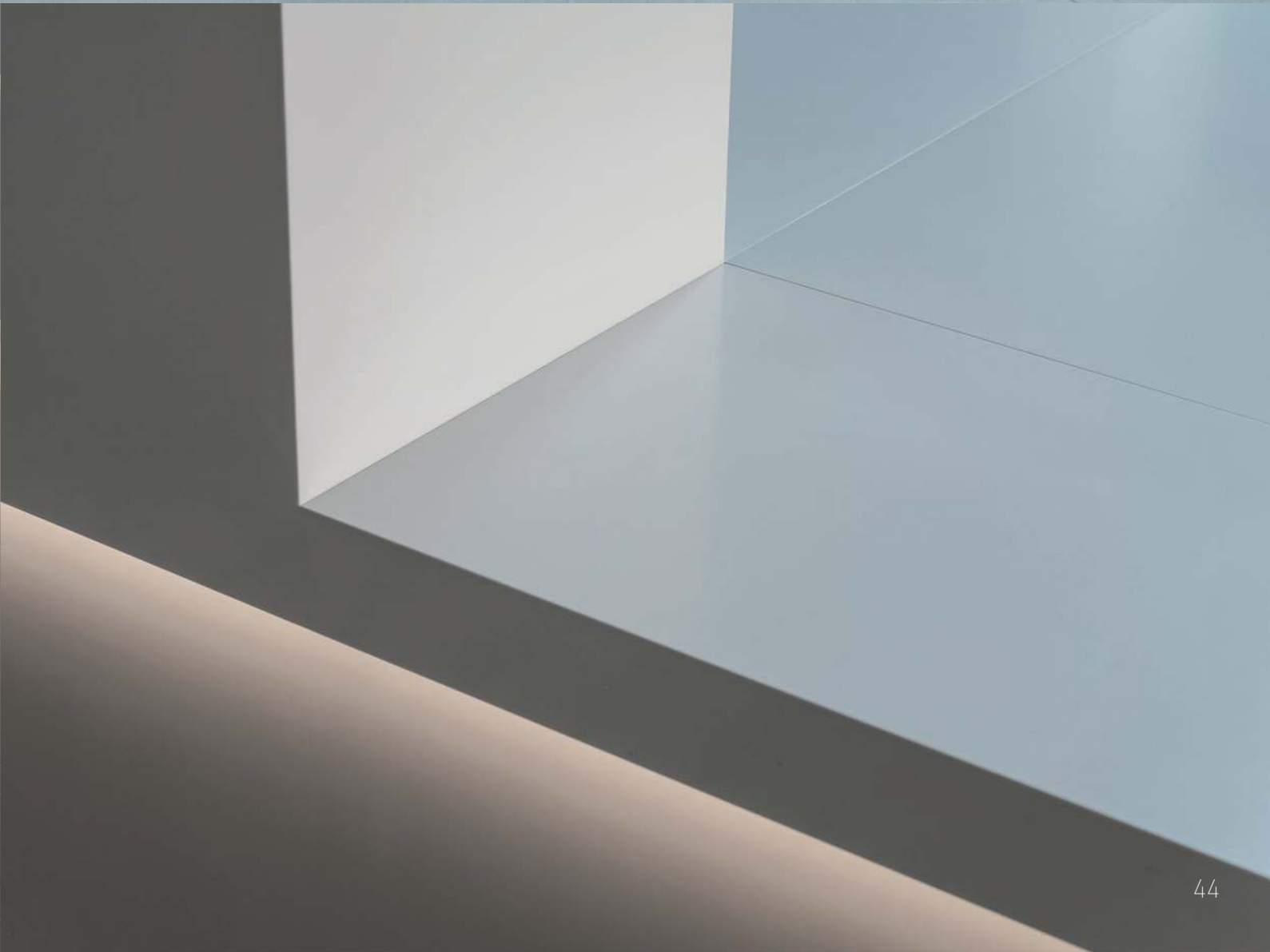



MOVIE

FLOWING CONTOURS

PROJECTING SURFACES

DUAL-TONE CONCEPT

FLOW

Fluid S-curves are evidence of formal continuity and timeless elegance. The dual-tone concept of black and white solid surface material creates a graphically expressive contrast. At the same time, these raised and receding surfaces balance the design and create balanced proportions. In terms of atmosphere, the effect is similar to flowing water or the surging of waves.

ADDITIONAL OPTION BACK OFFICE SOLUTIONS

Equipment including cable passages, compartments and standing containers are available for workspaces (see price list).

ADDITIONAL OPTION LOGO



Your logo can be integrated into the front panel of the counter on request.

miru milled
in module
FLO-S-U-900

miru attached

ADDITIONAL OPTION BASE LIGHTING

Base lighting is also available:

-  warm lighting (2.700 K)
-  cold lighting (4.000 K)

MODULE SELECTION

There are 22 modules to choose from, including lowered and accessible modules (see page 49).



JOINT DESIGN

You decide whether the modules are assembled with a visible design joint or are delivered joint-free. Joint-free processing of the material in one piece (including delivery) is possible at the factory up to a length of 4 metres and a width of 1.2 metres. If delivery of a joint-free product is not possible, the modules can be combined, bonded together, and sanded to a smooth gap-free finish on site for an additional charge.

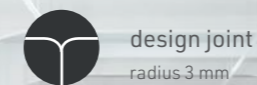

COLOUR OPTIONS

standard
Orchid White solid surface material



optional: two-tone front panel
The lowered modules are available in two colour combinations. The base colour can be selected in the case of the purely white version (see page 50).

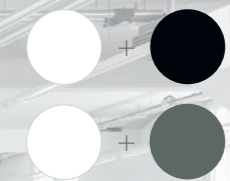

BASE COLOUR
white or coloured, the colour of the lower body in the case of two-tone option

ACCENT LIGHTING

MODULES + DECORS

Plan your individual design counter. Choose from 22 different modules. Create a colourful impression with a dual-tone colour combination in the solid surface material for the counter bodies. The data sheet provides further details on the modules (e.g. dimensions and weight) as well as potential configuration examples.

End Modules



Corner Modules

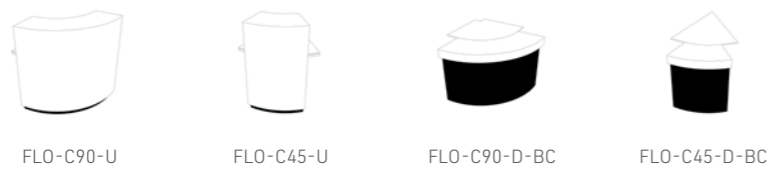

Straight Modules

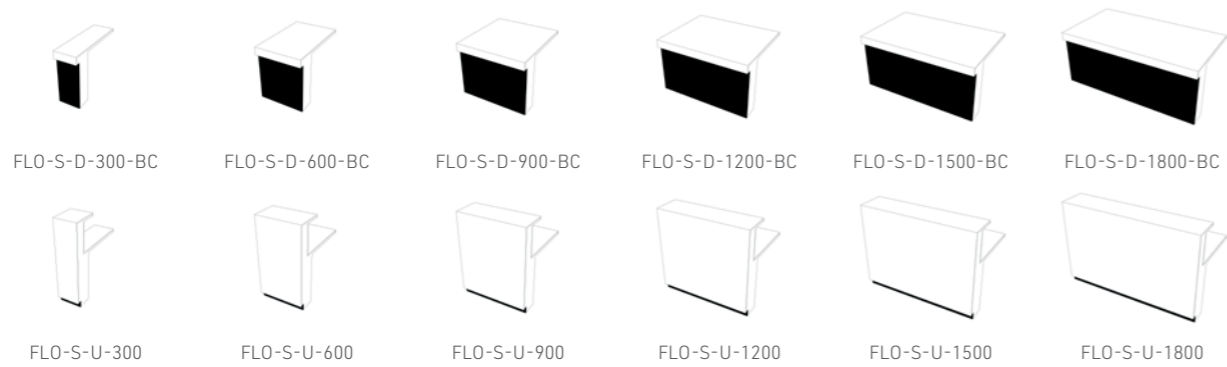

Transition Modules

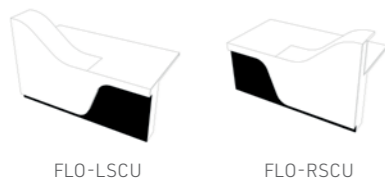

Standard: Solid Surface Material



ORCHID WHITE

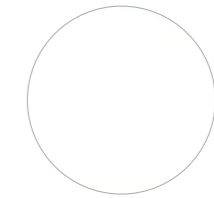

Alternative Colour For The Base As Well As In The Lowered And Transition Modules



ORCHID WHITE +
CURRANT BLACK

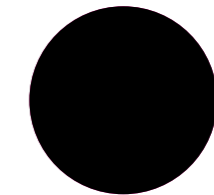

ORCHID WHITE +
BASALT GREY

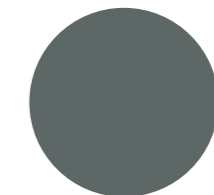

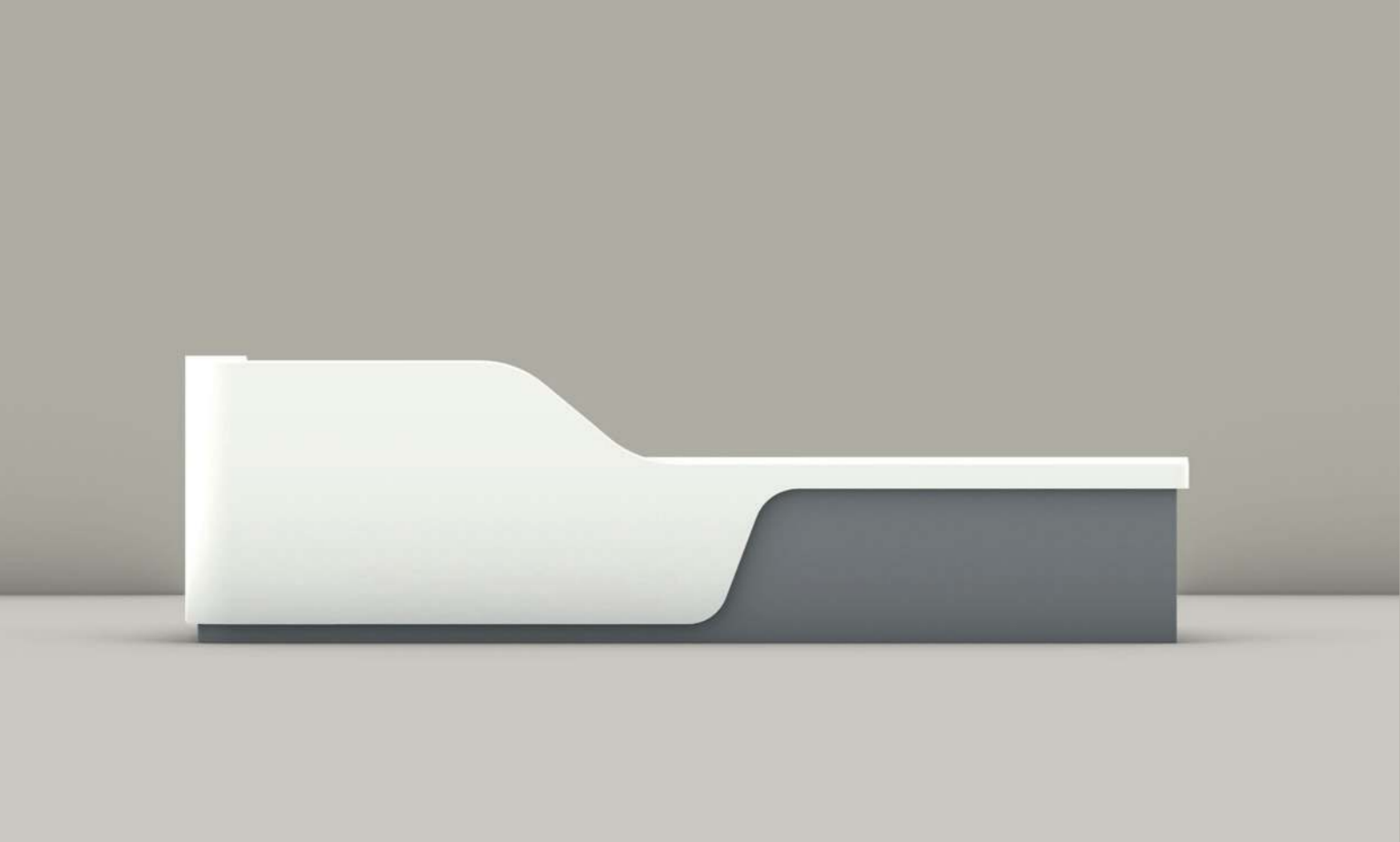





MOUNTAIN

POLYGONALLY
CONTOURED
SOLID SURFACE MATERIAL

CERAMIC INLAY
IN THE FRONT PANEL

CREATES AN IMPRESSION OF
EXPRESSIVENESS

MOUNTAIN

The interplay of the folded solid surface material with large-format ceramic plates creates an expressive yet natural-looking material contrast. The surfaces of the sintered stone (ceramic) shine out along a polygonal contour.

Memories of landscape formations are awakened. Mountains, crevasses, and geological phenomena resonate in this composition of smooth white solid surface material and haptically structured ceramic.



MODULE SELECTION

There are 22 modules to choose from (see page 59).

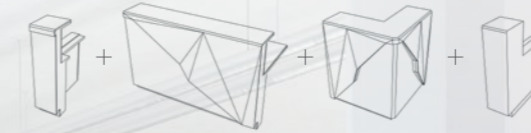

COLOUR OPTIONS

standard

Orchid White solid surface material combined with ceramic inlay New York - New York in the front panel



optional: alternative ceramic decors

Four additional ceramic decors are available (see page 60).



JOINT DESIGN

You decide whether the modules are assembled with a visible design joint or are delivered joint-free. Joint-free processing of the material in one piece (including delivery) is possible at the factory up to a length of 4 metres and a width of 1.2 meters. If delivery of a joint-free product is not possible, the modules can be combined, bonded together, and sanded to a smooth gap-free finish on site for an additional charge.



joint-free



design joint
bevel 2x2 mm

ADDITIONAL OPTION
LOGO

Your logo can be integrated on the ceramic front panel of the counter on request.





polygonally contoured
solid surface material

ACCENT LIGHTING

ADDITIONAL OPTION
BASE LIGHTING

Base lighting is also available:

-  warm lighting (2.700 K)
-  cold lighting (4.000 K)

ADDITIONAL OPTION
BACK OFFICE SOLUTIONS

Equipment including cable passages, compartments and standing containers are available for workspaces (see price list).

BASE COLOUR

Stainless steel finish

MODULES + DECORS

Plan your individual design counter. Choose from 22 different modules and five ceramic decors that can be combined with the white solid surface material. The data sheet provides further details on the modules (e.g. dimensions and weight) as well as potential configuration examples.

End modules



MTA-LE-P



MTA-RE-P



MTA-LE-V



MTA-RE-V

Corner modules



MTA-C90-P

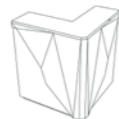

MTA-C90-V

Straight modules with folded solid surface material + ceramic

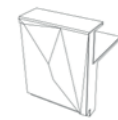

MTA-S-900-LP



MTA-S-900-RP



MTA-S-1800-LP



MTA-S-1800-RP

Straight modules with solid surface material in the front panel



MTA-S-300-V



MTA-S-600-V



MTA-S-900-V



MTA-S-1200-V



MTA-S-1500-V



MTA-S-1800-V

Straight modules with ceramic in the front panel



MTA-S-300-P



MTA-S-600-P



MTA-S-900-P



MTA-S-1200-P



MTA-S-1500-P



MTA-S-1800-P

Standard: Solid Surface Material + Ceramic



ORCHID WHITE +
NEW YORK - NEW YORK



Alternative Decors For Ceramic Surfaces



ORCHID WHITE +
AMAZONICO



ORCHID WHITE +
MAR DEL PLATA

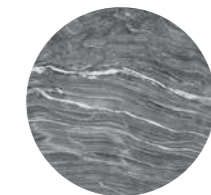

ORCHID WHITE +
STRATA ARGENTUM

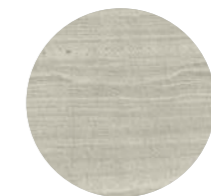

ORCHID WHITE +
TERRAZO CEPPO

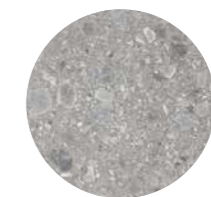

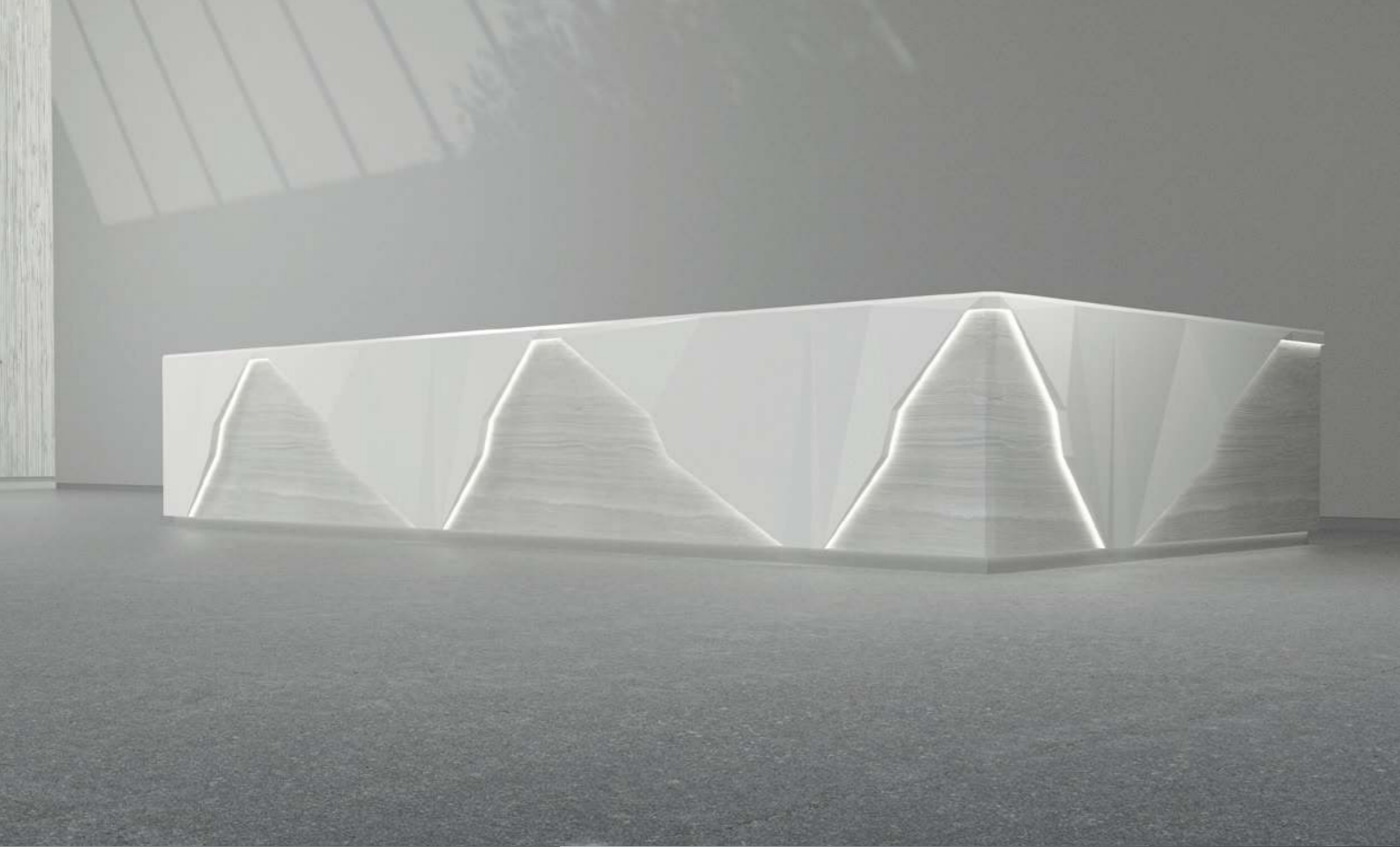





PRISMA

CERAMIC INLAYS

PROJECTING SURFACES

RHYTHMIC INTERPLAY

PRISMA

Pyramidal projecting surfaces of white solid surface material create a rhythmic play of light and shadow. The slightly inclined surfaces and the countertop can be finished with sintered stone (ceramic) inlays. Fine details in the material transitions are evidence of precise craftsmanship and give the bar a special value.



ADDITIONAL OPTION BACK OFFICE SOLUTIONS

Equipment including cable passages, compartments and standing containers are available for workspaces (see price list).

MODULE SELECTION

There are 22 modules to choose from, including lowered and accessible modules (see page 69).



JOINT DESIGN

You decide whether the modules are assembled with a visible design joint or are delivered joint-free. Joint-free processing of the material in one piece (including delivery) is possible at the factory up to a length of 4 metres and a width of 1.2 metres. If delivery of a joint-free product is not possible, the modules can be combined, bonded together, and sanded to a smooth gap-free finish on site for an additional charge.



joint-free



design joint
bevel 2x2 mm

COLOUR OPTIONS

standard

Orchid White solid surface material



optional: ceramic in prisms + countertop

Create accents in the front panel + countertop - with ceramic inlays. Three different decors are available (see page 70).



ADDITIONAL OPTION BASE LIGHTING

Base lighting is also available:



warm lighting (2.700 K)



cold lighting (4.000 K)

BASE COLOUR
white

MODULES + DECORS

Plan your individual design counter. Choose from 22 different modules. Create a unique impression with haptically structured ceramic inlays in the prisms and countertop. The data sheet provides further details on the modules (e.g. dimensions and weight) as well as potential configuration examples.

End Modules

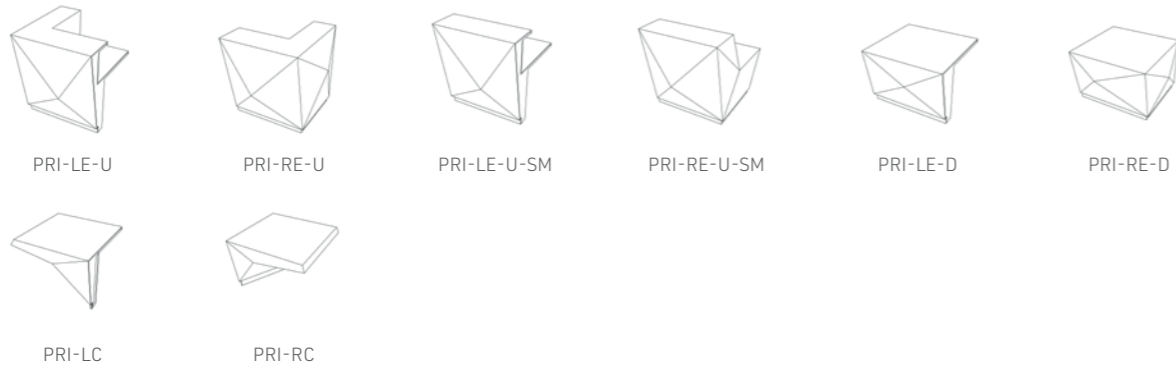

Corner Modules



Straight Modules

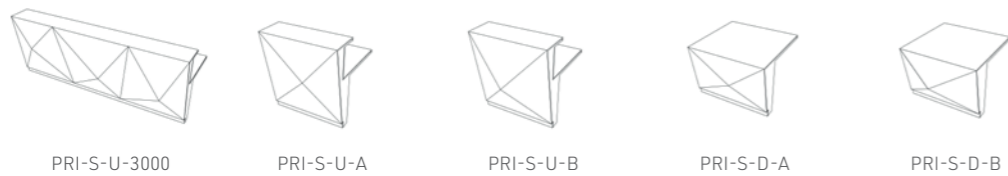

Accessible Modules

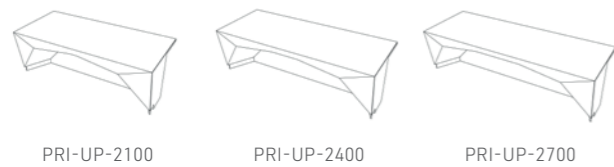

Transition Modules

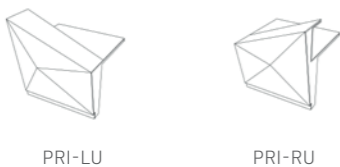

Standard: Solid Surface Material

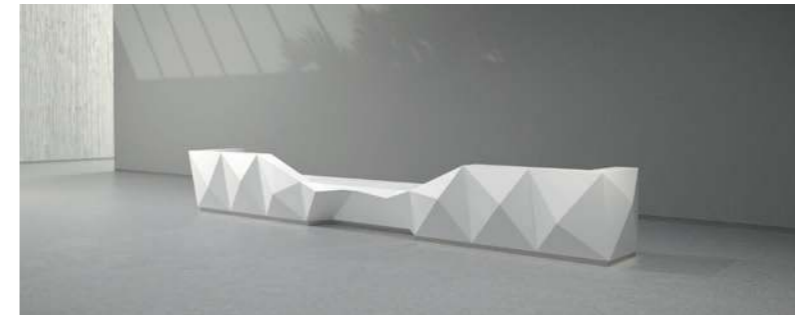

ORCHID WHITE

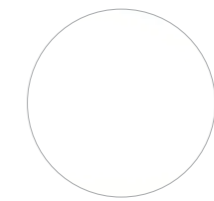

Alternative: Ceramic In Prisms + Countertop

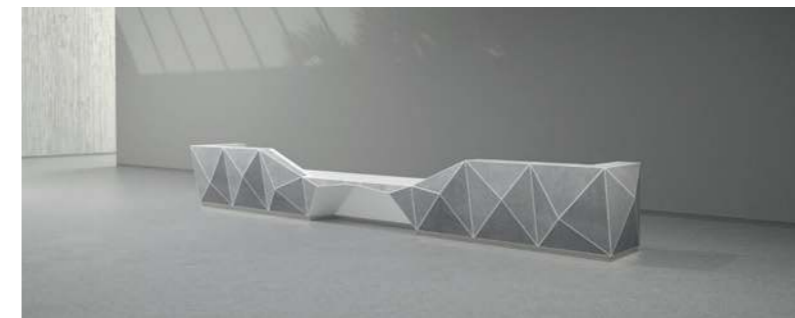

ORCHID WHITE +
IRON GREY

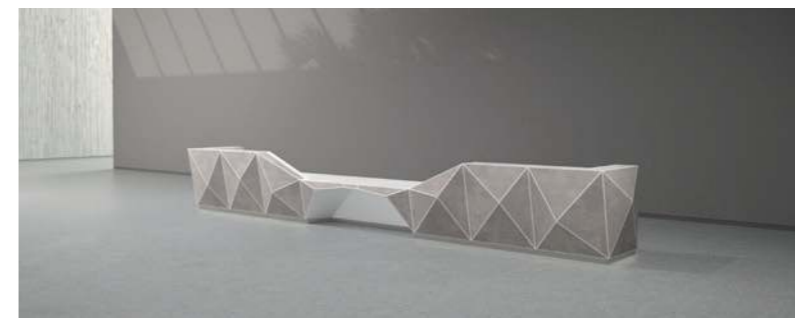

ORCHID WHITE +
NEW YORK - NEW YORK

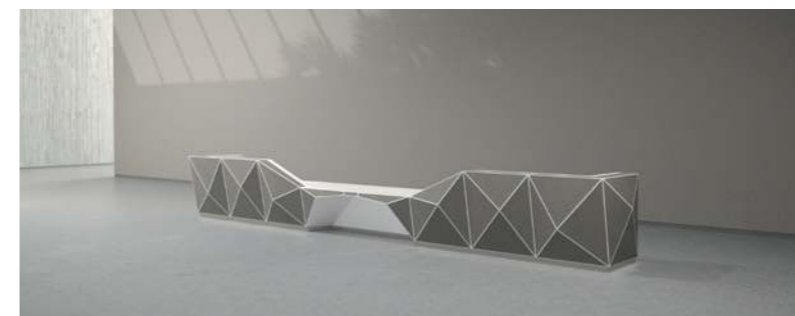
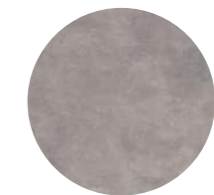

ORCHID WHITE +
PIETRA DI PIOMBO

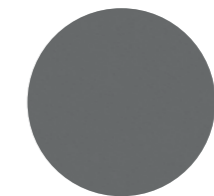

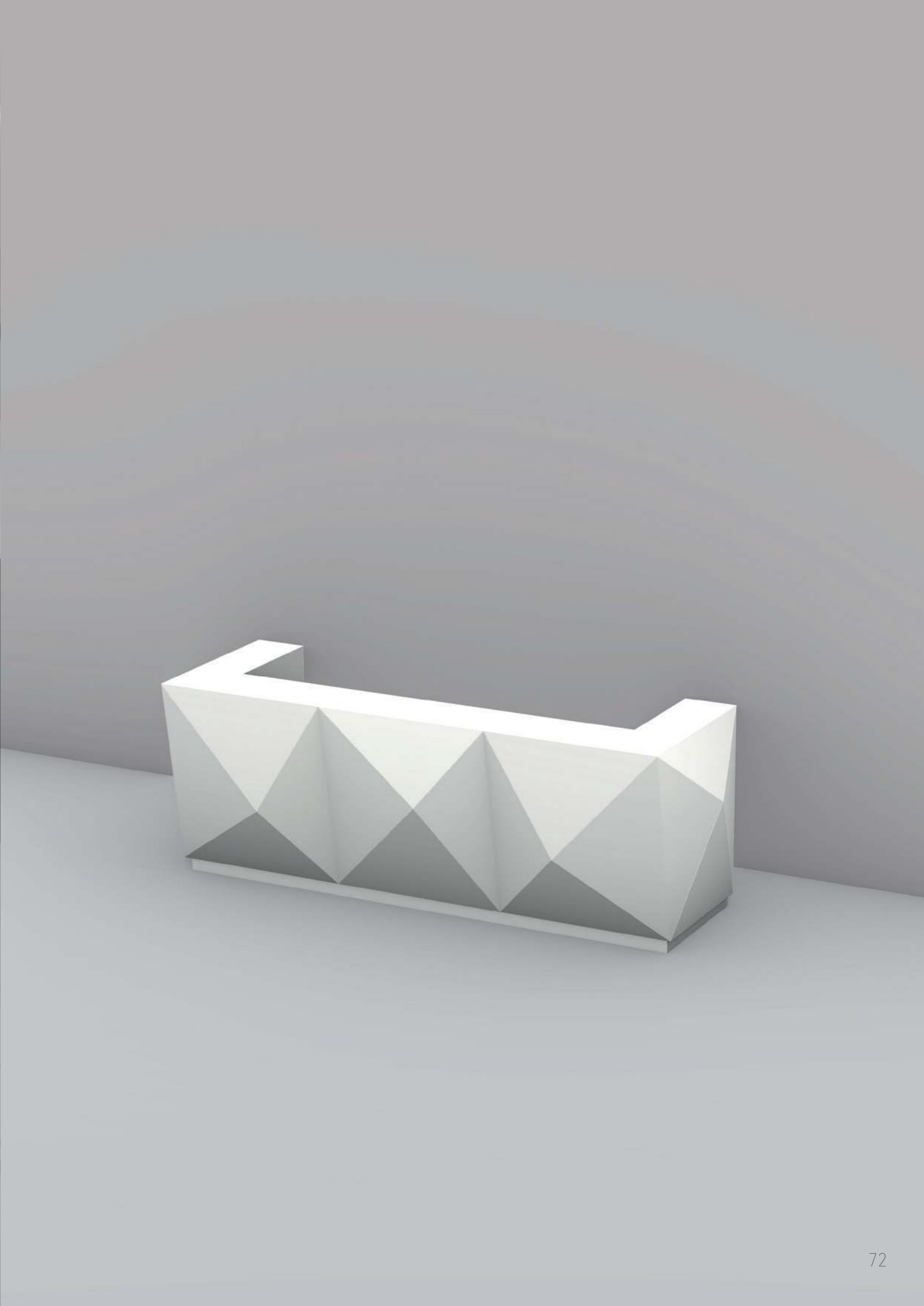
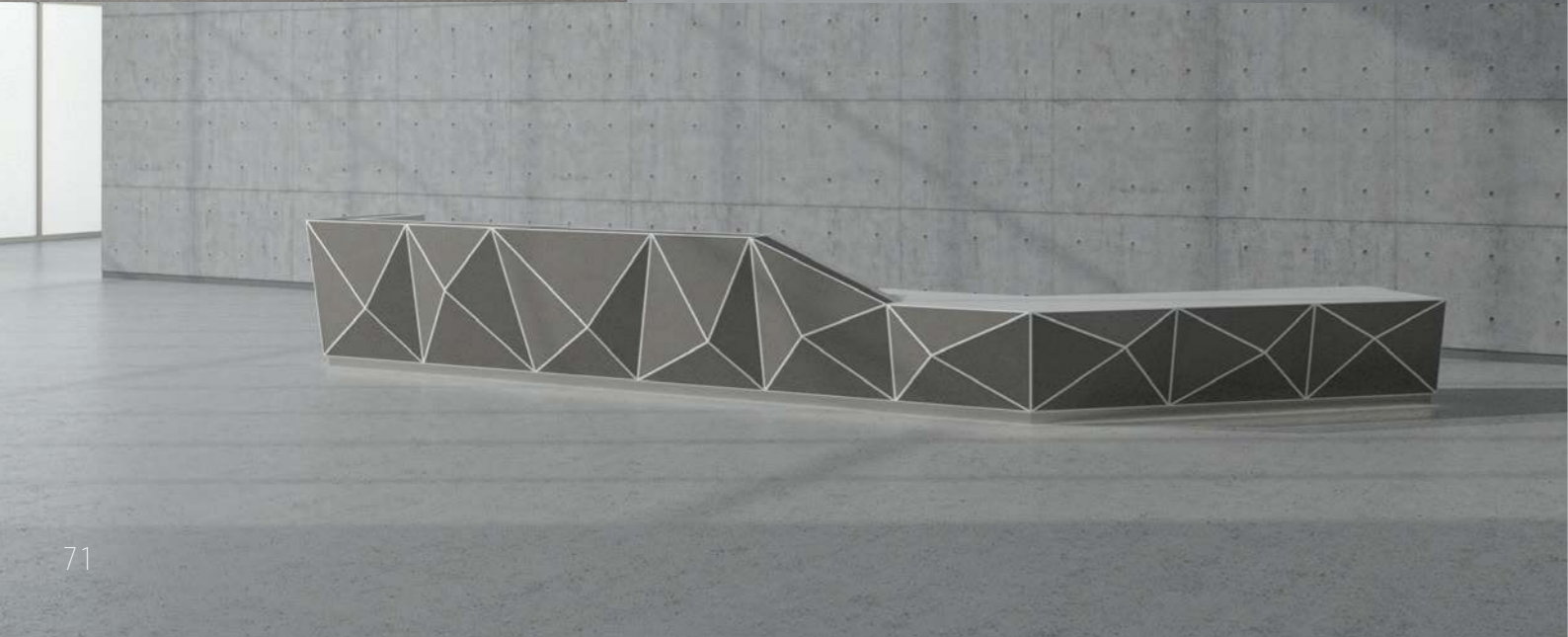
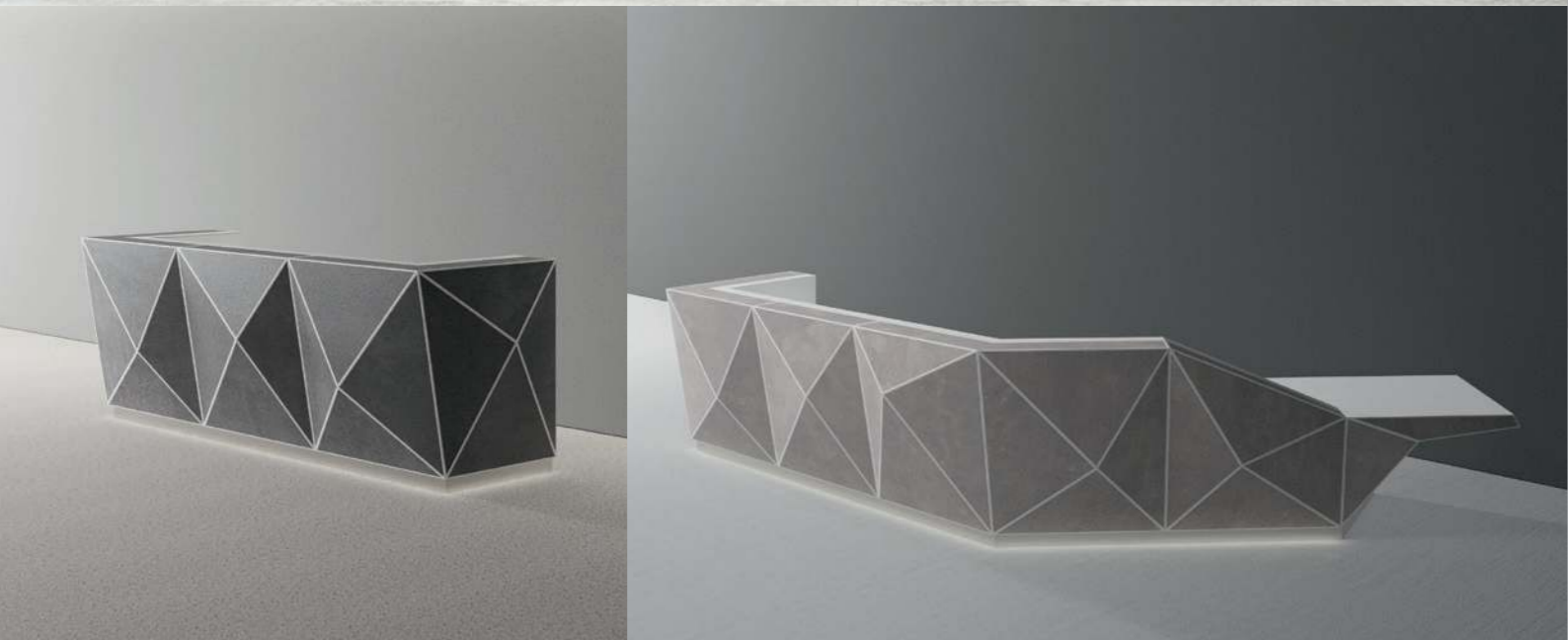



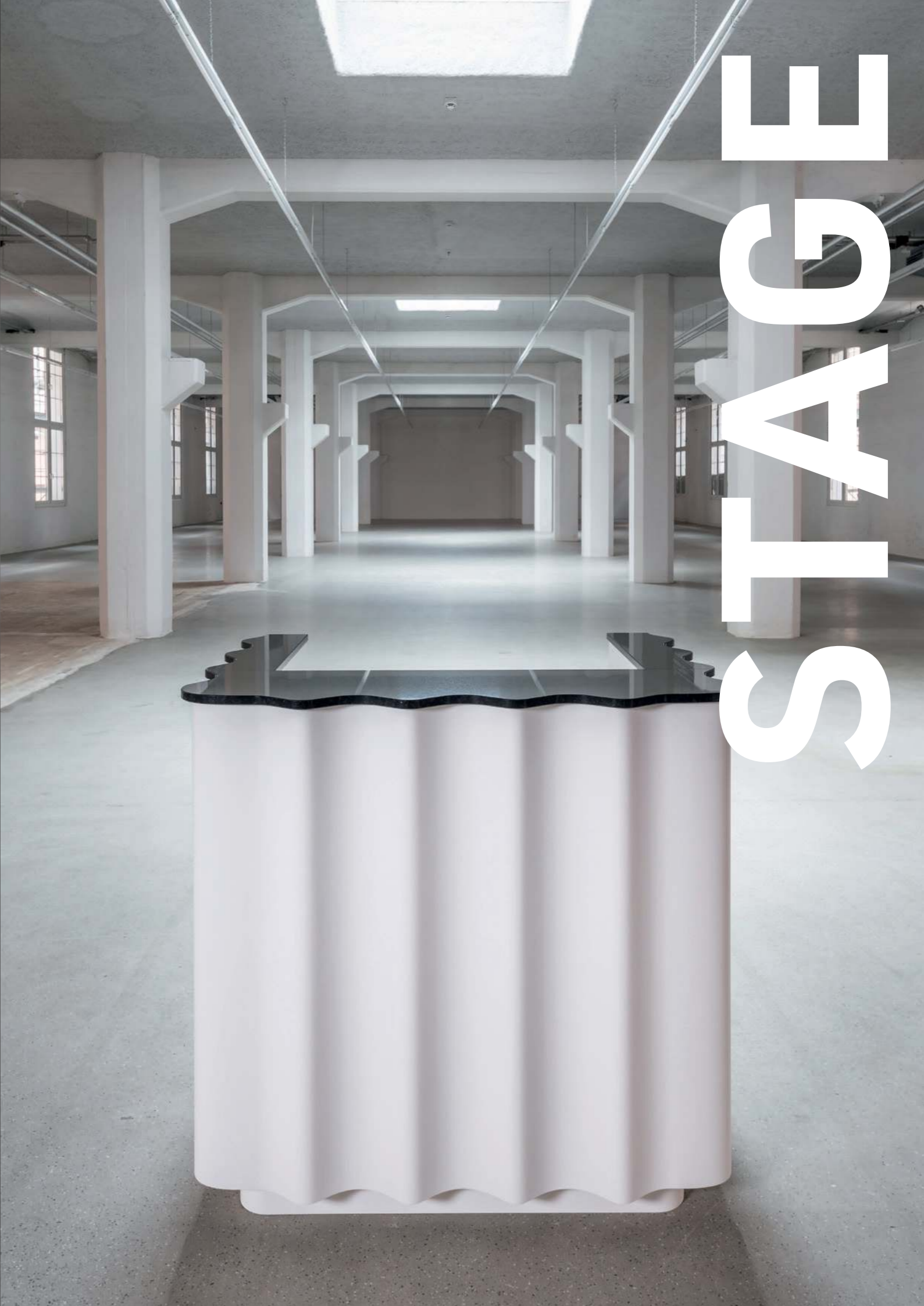

STAGE

NATURAL STONE COUNTERTOP

CURVED DRAPE

STAGED PLASTICITY

STAGE

With the impression of a flowing textile material, such as a stage curtain, Stage stages the plasticity of solid surface material in a curved drape. Like a vertical pilaster, the curves are continued into the worktop made of natural stone. The wave form is transferred from one material to the next, reminiscent of baroque stylizations that are echoed here in a contemporary design language.

ADDITIONAL OPTION BACK OFFICE SOLUTIONS

Equipment including cable passages, compartments and standing containers are available for workspaces (see price list).

MODULE SELECTION

There are 8 modules to choose from, including lowered and accessible modules (see page 79).

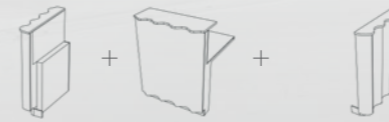

JOINT DESIGN

You decide whether the modules are assembled with a visible design joint or are delivered joint-free. Joint-free processing of the material in one piece (including delivery) is possible at the factory up to a length of 4 metres and a width of 1.2 metres. If delivery of a joint-free product is not possible, the modules can be combined, bonded together, and sanded to a smooth gap-free finish on site for an additional charge.

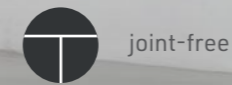

joint-free



design joint
radius 3 mm

COLOUR OPTIONS

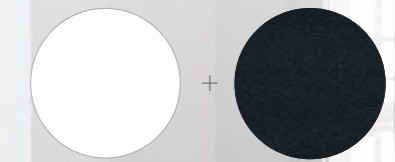

standard

Orchid White solid surface material + natural stone countertop Nero Assoluto (see page 80)



ADDITIONAL OPTION BASE LIGHTING

Base lighting is also available:

-  warm lighting (2.700 K)
-  cold lighting (4.000 K)

BASE COLOUR
white

MODULES + DECORS

Plan your individual design counter. Choose from 8 different modules. The combination of natural stone in the countertop with the white solid surface material underlines the plasticity of the staged drape. The data sheet provides further details on the modules (e.g. dimensions and weight) as well as potential configuration examples.

End Modules



STG-LE



STG-RE

Corner Modules



STG-C90



STG-C45

Straight Modules

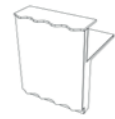

STG-S-AL



STG-S-BL



STG-S-BS



STG-S-AS

Standard: Solid Surface Material + Natural Stone In The Countertop



ORCHID WHITE +
NERO ASSOLUTO

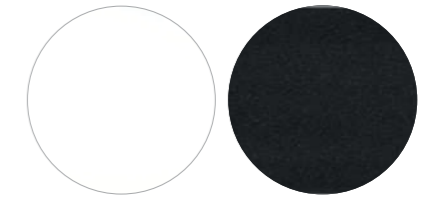

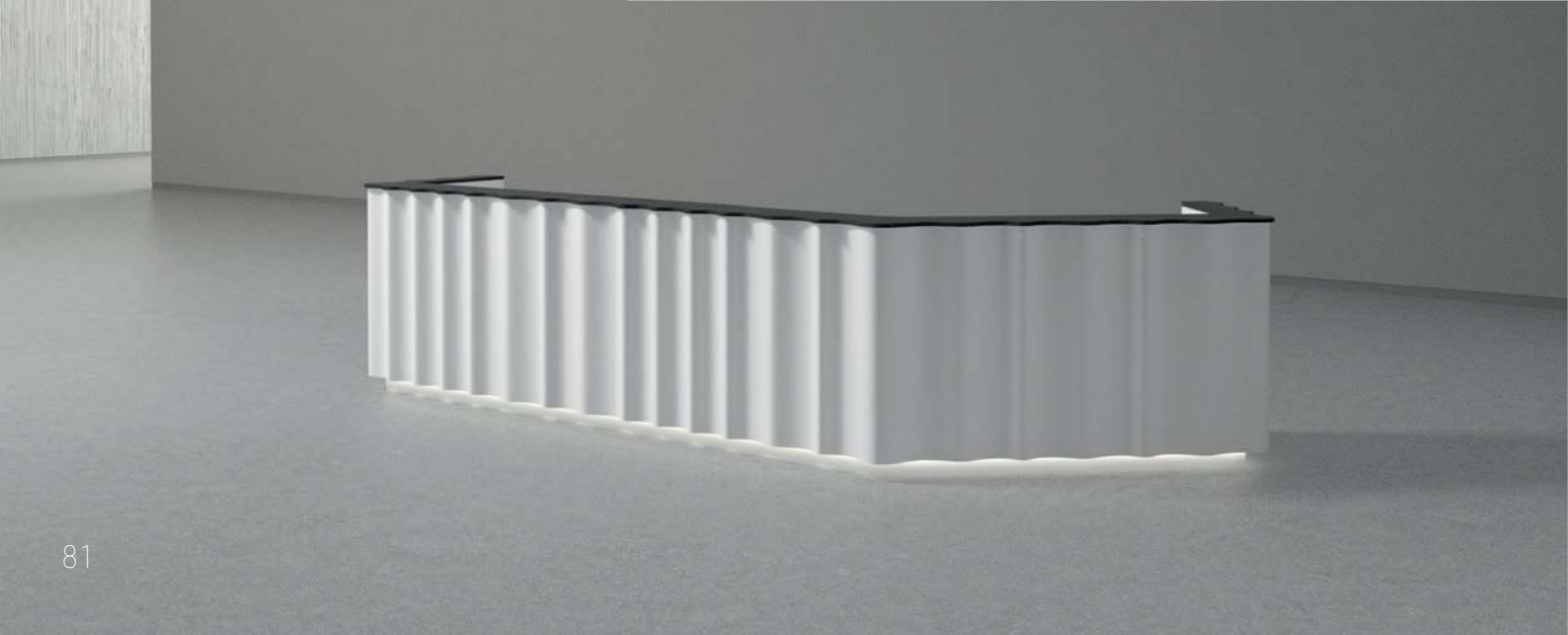





METALLIC PILASTER STRIPS

INTERPLAY OF CURVED + INDENTED SURFACES

MINIMALIST IN APPEARANCE

WARP



Minimalist simplicity combined with sweeping curves give this design its own aesthetic that can be described as sensual minimalism. Vertical, metallic inlays worked into the surface underline the dazzling expression of the shiny surfaces. Soft, flowing movements create a moment of playful lightness.

ADDITIONAL OPTION BACK OFFICE SOLUTIONS

Equipment including cable passages, compartments and standing containers are available for workspaces (see price list).

ADDITIONAL OPTION BASE LIGHTING

Base lighting is also available:

-  warm lighting (2.700 K)
-  cold lighting (4.000 K)

MODULE SELECTION

There are 8 modules to choose from, including lowered and accessible modules (see page 89).



JOINT DESIGN

You decide whether the modules are assembled with a visible design joint or are delivered joint-free. Joint-free processing of the material in one piece (including delivery) is possible at the factory up to a length of 4 metres and a width of 1.2 metres. If delivery of a joint-free product is not possible, the modules can be combined, bonded together, and sanded to a smooth gap-free finish on site for an additional charge.



joint-free



design joint
bevel 2x2 mm

COLOUR OPTIONS

standard

Orchid White solid surface material



optional: metallic pilaster strips

Create accents in the front panel with sophisticated metallic pilaster strips. Three different decors are available (see page 90).



BASE COLOUR
white

MODULES + DECORS

Plan your individual design counter. Choose from 8 different modules. Create a unique impression by integrating sophisticated metallic synergy3D pilaster strips within the body of the counter. One trio of pilaster strips can be placed per module, and one decor can be selected per bundle. The data sheet provides further details on the modules (e.g. dimensions and weight) as well as potential configuration examples.

End Modules



WAP-LE-U



WAP-RE-U

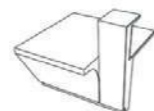

WAP-LE-D

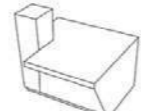

WAP-RE-D

Corner Modules

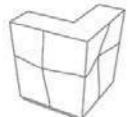

WAP-C90-U-BDE

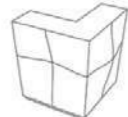

WAP-C90-U-DEB

Straight Modules



WAP-S-U-B



WAP-S-U-DE

Standard: Solid Surface Material



ORCHID WHITE

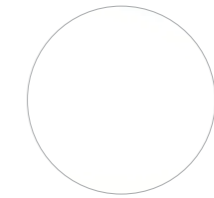

Alternative: Synergy3D Trio Of Pilaster Strips In The Front



ORCHID WHITE +
BRASS



ORCHID WHITE +
COPPER



ORCHID WHITE +
SMOKE

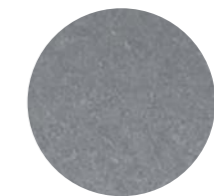







CRAFTSMANSHIP
MEETS
ARCHITECTURE



EXPERTISE



MADE IN GERMANY

With the decisive implementation of traditional craftsmanship, modern machinery and trending technologies, Rosskopf + Partner has been planning, designing, manufacturing and installing solutions for reception areas using solid surface material for over 35 years. Whether creating furnishings in classic shapes, sophisticated modern designs or by combining different materials – our team knows each of its products inside out. With the miru® modular design counters, we transfer decades of know-how and experience in cooperation with top designers and architects into a partially standardised system.

Investors as well as specialist planners, interior designers and architects and furnishers all benefit from rapid implementation, high planning transparency, state-of-the-art designs and individual solutions. At the same time, we continue to offer all interested parties individually designed and planned reception solutions - independent of miru®. Please feel free to get in touch.



MORE THAN RECEPTION SOLUTIONS

At our two locations, over 200 employees bring ideas to life: engineers, processing and installation experts develop diverse, customised and holistic solutions from solid surface material, ceramics, quartz and natural stone: wall and façade cladding, washbasins, furnishings for canteens and kitchenettes, exterior cladding and much more. The combination of materials is a frequent feature of our offering. As a full-service provider, we are at our customers' disposal from consultation to design to production and assembly.

Request more information now:
info@rosskopf-partner.com



**Kitchen worktops +
furnishings for canteens + kitchenettes**



Bathroom solutions



Wall cladding



Seating elements



Architectural projects

ROSSKOPF + PARTNER



Kitchen worktop
for kitchenette

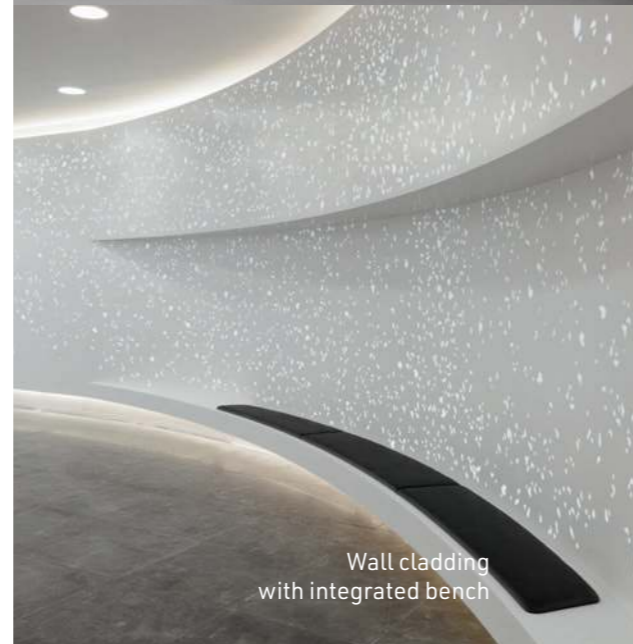

Wall cladding
with integrated bench



Washroom
for employees



MR Walls - unique 3D design walls;
special light effect possible through backlighting



Law firm Allen & Overy in Luxembourg – interior design according to a holistic design concept: filigree lettering elements for wall cladding, brochure wall, reception solutions as well as furnishings for the catering section

LEONARDO glass cube – company headquarters in Bad Driburg; organically shaped 'genetics' structures made of solid surface material

Photos Adobe-Stock (andrys lukowski, EpicStockMedia, loerke.foto, Milosz Maslanka, Natalya Vyshedko, ON-Photography, Volodymyr), Andreas Mikutta, diephotodesigner, Darius Ramazani, edel-fotografie, Emanuel Raab, Heiko Stahl, Johannes Willwacher, Marc Willson, M|R Walls, Neolith, Ralph Richter, Rennerod / Ben Schumann, Shutterstock (Maren Winter), Steffen Spitzner, Sven Rahm, Tobias Serf, VBA
Design KOPFSATZ GmbH • www.kopfsatz.de

ROSSKOPF + PARTNER AG

Headquarters Am Flugplatz 3, D-99994 Nottertal-Heilingen Hoehen OT Obermehler

Phone +49 (0) 36021 9899-3000 • **Fax** +49 (0) 36021 9899-10

Email miru@rosskopf-partner.com • **Web** www.rosskopf-partner.com
